

## MiX2000 Installation Manual



## Table of Contents

1	Introduction .....	3
1.1	MiX 2000 Hardware Features .....	3
1.2	MiX 2000 Power Requirements .....	4
2	Read Before Installation: .....	4
2.1	Installer Requirements.....	4
2.2	Tools.....	4
2.3	Secure the workplace.....	4
2.4	Precautions.....	5
2.4.1	ESD .....	5
2.4.2	Water Seal .....	5
2.4.3	During installation .....	5
2.4.4	Positioning of product components .....	5
2.4.5	Installation of Wiring .....	6
2.4.6	After Installation.....	7
2.4.7	Take Note During Operation .....	7
3	Part Numbers.....	7
4	Preparing the SIM card.....	9
5	How to open and close the unit (MiX 294E-2G-B).....	9
6	How to insert an external GNSS antenna (MiX 294E-2G-B).....	13
7	Installation.....	16
7.1	Installation Requirements .....	16
7.2	Summary of Installation Steps .....	16
7.3	Overview.....	16
7.4	Tools and inspection .....	16
7.5	Wiring and Connections .....	16
7.5.1	3-wire Ignition Harness .....	17
7.5.2	14-Wire Fleet Harness.....	17
7.6	Beep codes.....	17
7.7	LED flash codes .....	18
7.7.1	GNSS LED flash codes (GREEN).....	19
7.7.2	GSM LED flash codes (RED).....	19
7.8	Starter Interrupt.....	20
7.8.1	Positioning the MiX 2000 Unit in the vehicle.....	21
7.9	Signal Inputs .....	22
7.9.1	Digital Inputs.....	22
7.9.2	Ignition Input.....	23
7.10	Power Outputs .....	23
7.10.1	External Relay Drives .....	23
7.11	Serial Communication .....	23
7.12	Configuration of unit .....	23
7.13	GNSS antenna connection .....	24
8	Troubleshooting .....	24
9	Maintenance .....	25

# 1 Introduction

The latest evolution of the MiX 2000 product line sees a departure from the previous single version hardware product (MiX 2310i) for both consumer and fleet applications. There are now two dedicated hardware configurations, namely:

- a) Fleet (MiX 294E-2G-B) - Supplied in an IP65 enclosure with two digital inputs, a relay drive output, a socket for connecting an external GPS antenna and a blue plug driver ID reader.
- b) Consumer (MiX 294D-2G-B) - Supplied in an IP54 enclosure and has none of the peripherals listed above for the fleet version.

Both variants share the built-in 2G modem, have an internal backup battery, a 3-axis accelerometer, an ignition input and a 434 MHz short range transceiver.

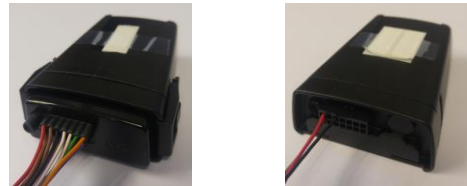

## 1.1 MiX 2000 Hardware Features

Features	Model	MiX 294E-2G-B FLEET	MiX 294D-2G-B CONSUMER
	Part Number	440FT0057	440FT0064
	Category	Entry level Fleet	SVR
	Modem	SARA-G450 (2G)	SARA-G450 (2G)
	Magix (SRD)	434 MHz	434 MHz
	IP Rating	IP65	IP54
	GNSS	ZOE-M8Q	ZOE-M8Q
	SIM card	Nano SIM (4FF)	Nano SIM (4FF)
	Serial communication for debugging and configuration	RS-232	TTL
	<b>Description</b>	<b>Number per variant</b>	
<b>Digital Inputs</b>	Digital inputs can be configured to monitor any device that generates a change in voltage, e.g. seat belts, headlights, refrigeration units, temperature sensors, emergency lights, doors, PTO, UDS, trailer coupling etc.	2	0
<b>Relay Output</b>	The relay drive output can be used to drive a relay. The output impedance (driving low) is less than 1.5 Ohm.	1	0
<b>Buzzer</b>	A buzzer (incorporated as part of the harness) to warn the driver and provide feedback on the vehicle's status.	1	0
<b>LED</b>	LEDs provide feedback on the status of the unit.	2	2
<b>Ignition Input</b>	Used to monitor the ignition switch status. Maximum 33V input, impedance > 100kOhm.	1	1
<b>Internal Backup Battery</b>	An internal battery provides power for between 4 and 8 hours if the supply from the vehicle's battery is removed.	1	1
<b>Code Plug</b>	Driver Identification	1	0
<b>Mounting Clip</b>	Provision for convenient mount and dismounting	1	1
<b>Supply</b>	10.5 – 33 V DC	1	1

## 1.2 MiX 2000 Power Requirements

The MiX 2000 is designed for use in vehicles (12V to 24V). Special vehicles and working machines with a 24 to 110 volt DC battery system will require a voltage converter to facilitate the required 12V to 24V power supply input.

The power and ignition lines must be installed with the fuses (rated 7.5 A) supplied inside the power harness plastic bag.

## 2 Read Before Installation:

### 2.1 Installer Requirements

- Installation should only be undertaken by a vehicle technician with comprehensive occupation specific knowledge. Installation by an unqualified technician may adversely affect the operating reliability of the vehicle and could endanger other road users.
- A basic knowledge of vehicle electrical and mechanical systems is required to successfully install the Fleet Manager system.
- The system should only be installed by a suitably qualified vehicle technician with a basic knowledge of the operation of computers.
- Installation technicians should attend a training course to acquire the skills needed for installation, configuration and operation of the Fleet Manager system.
- Installers should consult the vehicle manufacturer's documentation for the specific vehicle make and model prior to undertaking an installation.
- Installers should pay particular attention to the location of fuel systems, hydraulic systems, compressed air systems and other electrical and mechanical systems, which may have a bearing on the installation.
- Installers should pay attention to any changes to the vehicle's systems or settings, which should be noted prior to the installation.
- Installers should not smoke or make use of naked flames, which could cause a fire in or near the vehicle.

### 2.2 Tools

- Standard technical equipment and appropriate tools for use with vehicles are required to install the MiX 2000.
- Vehicle specific tools may be required for the removal of consoles and covers.

### 2.3 Secure the workplace

- Remove the ignition key from the vehicle's ignition lock.
- Ensure that the vehicle's engine cannot be unintentionally started during the installation.
- Short-circuiting the vehicle's electrical system may result in fire, explosion of the battery and/or damage to other electrical systems.
- Electrical shock from high voltage batteries must be avoided, as this may lead to death or injury.
- The negative terminal of the vehicle's battery should be disconnected before commencing installation. If the vehicle has additional batteries, it may be necessary to disconnect the negative terminals of these batteries too.

## 2.4 Precautions

### 2.4.1 ESD

Prior to touching the PCB, replacing the battery or retrieving a SIM that has fallen into the housing, always take ESD precautions:

- Remove the main harness connector.
- Touch the gold portion of the GNSS connector to get to the same potential as the unit.
- If the PCB must be handled, avoid direct contact with any of the components and handle it by only touching the edges of the PCB.

### 2.4.2 Water Seal

Care must be taken not to compromise the water seal of the unit when opening and closing the unit to insert the SIM card (i.e. damaging any of the rubber seals). Compromising the water seal may result in water ingress and ultimate failure in the field.

- Avoid direct side forces on the wires exiting the rubber seal.
- Allow at least 2 cm straight wire on the exit of the harness wire before bending them side wards.
- Use a cable tie (or anti-tampering seal) enclosing the side clips to avoid the side clips from opening accidentally.

### 2.4.3 During installation

Should it be necessary to remove seats, covers or other components, care should be taken to avoid accidental damage and/or disconnection of cables.

- All components should be checked for damage prior to being installed into the vehicle.
- For small installation openings, a drill should be used.
- For larger openings, a conical milling cutter, compass saw or file should be used.
- All rough edges should be trimmed.
- Careful attention must be paid to the manufacturers' safety regulations for all tools used.
- Oils and fuels must be collected in appropriate containers and disposed of in accordance with the law.

### 2.4.4 Positioning of product components

Installers should ensure that the components of the product do not influence or hamper the functioning of the vehicle's systems.

- Care should be taken to ensure that the product's components do not get damaged during installation.
- Ensure that sufficient space is available for all components of the product, prior to commencing the installation.
- Should the bracket be used to fix the unit to the vehicle, make sure that the unit and bracket are securely clipped together. Add a cable-tie around the complete housing and bracket assembly for a more secure mounting if required.
- Avoid installing in known high-temperature areas, such as parts of the engine bay or near major heat sources.
- Ensure that the unit and harness are secured to prevent the harness vibrating differently to the unit at the harness connectors.
- Correct orientation of the unit is important to ensure good GNSS reception if the internal GNSS antenna is being used. In This case, the unit should be mounted with the rounded surface facing up, and the label side down. Additionally, it is advisable to install the unit in a

location where the GNSS view of the sky is relatively unobstructed by metal. Most vehicle boots for example, may form a metal cage which prevents GNSS reception. Under the vehicle bonnet will also not give good performance.

This side facing up

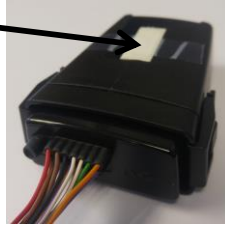

- Please note that the voltage of the external relay is rated to the vehicle voltage specification. Do not run a 12V relay at 24V. The Relay Specifications are:
- Coil current rating: < 200 mA
- Coil Voltage Rating: Must match the vehicle battery supply
- Please pay attention to the routing course of cables and wiring.
- Do not install the product in or near the location of mechanical or electrical airbags.
- Do not drill into supporting or stabilizing braces or beams.

## 2.4.5 Installation of Wiring

Note the product's wire gauge cross-sectional area. If the wire gauge cross-section is reduced, current density increases which may cause the wiring to overheat.

- Cables should be routed in existing channels and should not be routed parallel to ignition cables or other cables subject to high current.
- Cables should be fixed with cable-ties or adhesive tape.
- Do not route cables over moving parts or too close to the high voltage areas (like the spark plugs).
- Do not fix cables on the steering column.
- Ensure that the cables are not exposed to pulling, pressure or shearing deformation.
- If the cables are routed through drilled holes, rubber grommets or similar protection should be used.
- Suitable cable-strippers should be used to strip insulating material from cables and cable-strippers should be adjusted to suit the wire gauge being stripped, to avoid damaging or separating the wire strands.
- Cables should only be connected using solder or suitable crimping lugs.
- A proper crimping tool should be used on all crimping lugs.
- Careful attention must be paid to the manufacturers' safety regulations for all tools used.
- Insulate all exposed wires to prevent short-circuits. Use good quality adhesive tape or heat shrink (provided).
- Connections to vehicle power supply and the ignition wire **must be installed with a fuse**. Fuses are supplied separately inside the main harness plastic bag.
- Be aware that short-circuiting may be caused by faulty connections and crushed or damaged cables.
- Short-circuiting the vehicle's electrical system may result in fire, explosion of the battery and/or damage to other electrical systems. To prevent this, all connections carrying current must be soldered and insulated correctly. Other connections such as the speed signal, RPM signal, brake light or clutch switch can be made with crimping lugs.

- Incorrect connections can lead to short circuits. Connections should only be made in accordance with the vehicle's wiring diagram.
- Current and voltage should be measured with a multi-meter or diode test lamp.
- The use of inadequate test equipment may result in damage to control devices or other electrical systems.
- Route the harness in such a way as to prevent water condensation that may form on the cable from running into the unit. This can be achieved by having the harness at a lower point just before it connects to the unit.

### 2.4.6 After Installation

- Check all relevant vehicle functions.
- Explain the functions of the MiX 2000 system to the user.
- The MiX 2000 contains an internal battery which should be inspected annually.

### 2.4.7 Take Note During Operation

- The product must be operated in accordance with operating instructions.
- Failure to use the product as directed might result in personal injury, material damage and/or damage to the environment.

## 3 Part Numbers

Part Number	Used	Name	Picture
440FT0057	FLT	MiX 294E-2G-B MiX 2000 <b>2G Fleet</b> Type 4 Electronic Unit (contains fitted battery)	
440FT0064	CSR	MiX 294D-2G-B MiX 2000 <b>2G Consumer</b> Type 4 Electronic Unit	
A0013MT	FLT	Main Harness MP12	
A0014MT	FLT	OBDII Power Harness MP13	

A0012MT	CSR	Power Harness MP11	
<b>Driver ID add-on : Add these components only when Driver ID is going to be installed</b>			
440FT0623	FLT	Code Plug Socket Harness and Clip	
440FT0073	FLT	Blue Driver Plug	
<b>Optional Extras: Add to order only when required</b>			
440FT0785	Both variants	MiX 2000 mounting clip	
440FT0694	FLT	GNSS antenna	
440FT0681	FLT	MiX 2000 Serial Programming Harness	
A0015MT	FLT	Serial Programming Harness SR5	
A0027MT	CSR	Serial Converter Harness SR6	



## 4 Preparing the SIM card

Caution: Be careful to use only nano SIM (4FF) with the standard thickness. Cutting a micro SIM to a 4FF size may damage the SIM card holder.

Before inserting the SIM card determine if the SIM needs to be secured with a unique PIN.

If a PIN secured SIM is required:

- Ensure that the SIM is configured as “PIN required”
- Ensure that the PIN is set as either 0000 or 00000
- The MiX 2000 will change the PIN to a unique number that it calculates for the device
- The SIM is then locked to the device and will be PUK locked if inserted in another device

If an unsecured SIM is required:

- Ensure the SIM is configured as “PIN not required”
- The MiX 2000 will leave the SIM with this configuration
- This SIM can be moved to a different device without risk of it being PUK locked

## 5 How to open and close the unit (MiX 294E-2G-B)

1. Open the side clips as illustrated in Figure 1 and Figure 2
2. Unhook clips as illustrated in Figure 3
3. Remove outer faceplate in order to expose the SIM card slot as shown in Figure 4
4. Insert SIM card as indicated in Figure 5
5. Ensure the SIM card is fully seated as shown in Figure 6
6. Insert and feed harness through outer face plate connector opening as shown in Figure 7
7. Ensure that the connector is fully inserted as shown in Figure 8
8. Clip on the face plate as shown in Figure 9
9. Close clips as shown in Figure 10 and Figure 11



**Figure 1 Opening of side clips**



**Figure 2 Opening of side clips**



**Figure 3 Unhook side clips**



**Figure 4 Remove outer faceplate**



**Figure 5 Insert SIM card**



**Figure 6 Ensure SIM card is fully seated**



**Figure 7 Insert harness through face plate**

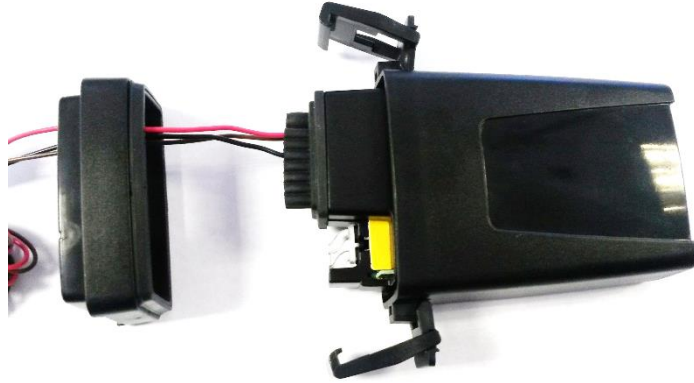

**Figure 8 Insert the connector**



**Figure 9 Clip on the face plate**



**Figure 10 Close clips**



Figure 11 Ensure clips are secured

## 6 How to insert an external GNSS antenna (MiX 294E-2G-B)

In order to insert the optional external GNSS antenna through the rubber wire seal, follow these steps:

1. Make a small hole (2-3 mm) at the end of the designated extended portion of the GNSS wire seal. Be careful not to make the hole too wide. It is recommended to use a sharp side cutter. See Figure 7.
2. Insert the GNSS connector through the opening in rubber seal (see Figure 12).
3. Make sure the rubber seal is evenly enclosed (see Figure 13).
4. Feed rubber seal with wires and GNSS cable through the outer face plate (see Figure 14).
5. Ensure that the connectors and outer face plate are fully seated (Figure 15).
6. Close the side clips (Figure 16).

**IMPORTANT:** Make sure the GNSS connector is seated properly. It is advisable to leave enough slack and then tie the GNSS to the main harness with a cable tie as a strain relief measure (Figure 17). This will eliminate the possibility of the GNSS connector being inadvertently dislodged by strain on the GNSS cable.



Figure 7 Cut hole in rubber



**Figure 12** Insert GNSS antenna connector



**Figure 13** GNSS antenna connector inserted



**Figure 14** Insert GNSS antenna connector and place outer face plate



**Figure 15** Insert GNSS antenna and 14-pin connector into sockets



**Figure 16** With GNSS antenna inserted, close the side clips



**Figure 17** Allow enough slack and tie GNSS antenna securely to main harness

## 7 Installation

### 7.1 Installation Requirements

Please note the requirements specified in the “Safety” section of this document.

### 7.2 Summary of Installation Steps

Step	Action	Software Tools
1)	Install harness	None
2)	Install code plug socket	None
3)	Install GNSS antenna	None
4)	Ensure the SIM is correctly prepared (refer to section 4)	
5)	Insert the SIM card (refer to ESD precautions in section 2.4.1). The SIM card orientation is illustrated in Figure 5. SIM card preparations are described in section 4.	None
6)	Connect power and signal inputs	None
7)	Test Installation	Verify that the unit reports to the Back End
8)	Test GSM observing the LED flashing sequence (see section 7.7.2)	None
9)	Test GNSS observing the LED flashing sequence (see section 7.7.1)	None

### 7.3 Overview

Installation of MiX 2000 should only be carried out by trained installers.

- On the MiX 2000, the unit maintains an on-board GNSS odometer. This starts at 0 km from the factory. An offset can be sent from the MiX Telematics Fleet Manager user interface to align the odometer value on the MiX 2000 unit with the vehicle odometer at install time. An updated value can be sent at any time to realign these two values.
- It is important to select the correct mounting location for the MiX 2000. Do not mount close to air ducts that can channel cold or hot air directly onto the unit.
- The Unit contains an internal GSM antenna and should be mounted more than 20cm away from the human body under normal operating conditions.

After installation, verify that no interference is caused to the vehicle’s electrical system. Check dashboard warning lights and error messages. Should any error conditions exist, remove the installed unit and contact MiX Telematics for assistance.

### 7.4 Tools and inspection

Supporting tools

Multi-meter

### 7.5 Wiring and Connections

Please read the “Safety” section of this document before installing the vehicle harness.

Confirm which of the harnesses will be used in the install as the wire colours will differ depending on the harness selected. All connector diagrams are shown from the back (wiring side) of the harness.



The pin lay-out and wire colours of the various harness options as well as detailed tables describing pin functions are shown below.

### 7.5.1 2–Wire Power Harness (Compatible with 440FT064 MiX 2000 2G Consumer)

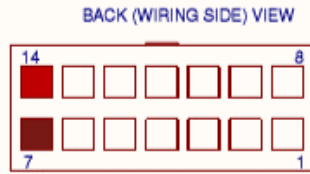

Pin	Colour	Name	Function
7	Brown	GND	Supply ground
14	Red	BAT+	Vehicle battery +

### 7.5.2 14-Wire Fleet Harness (Compatible with 440FT057 MiX 2000 2G Fleet)



	Colour	Name	Function
1	Purple	RXD	RS232 receive data
2	Red	LED	Code plug LED
3	White	CPCK	Code plug clock
4	Yellow/Green	Buzzer	Buzzer out
5	Black	GND	Ground to code plug
6	Blue/White	Reserved	Reserved
7	Brown	GND	Supply ground
8	Orange	TXD	RS232 transmit data
9	Green	CPDATA	Code plug data
10	White/Red	I2	Input 2
11	White/Violet	I1	Input 1
12	Black	IGN	Ignition input
13	Brown/Blue	Relay	Relay drive output (sink)
14	Red	BAT+	Vehicle battery +

## 7.6 Beep codes

The MiX 2000 has an output that drives a buzzer. The buzzer is not included inside the enclosure but is part of the 14-wire fleet harness. If any of the other reduced wire count harnesses are installed beep codes will not be audible.

The following beep codes will apply when a harness with an external buzzer is installed:

- Double beep when the device reboots or is powered up from shipping mode
- Triple beep when an over speeding, harsh braking, harsh acceleration or harsh cornering event occurs

- Continuous slow beeping at trip start for the duration of the user configured driver ID prompt period (When a valid driver ID is inserted two short beeps will sound and the slow prompt beeps will stop – Default driver ID prompt period is set to zero seconds, disabling the driver ID prompt)
- Five very short beeps when new config is sent to the device (This will typically happened when the first config settings are sent to a new device during a successful first connection. This will repeat every time any adjustment is made to device configuration or settings, such as adjusting an over speeding threshold)

## 7.7 LED flash codes

The MiX 2000 has 2 LEDs for diagnostic purposes. Refer to the picture below.

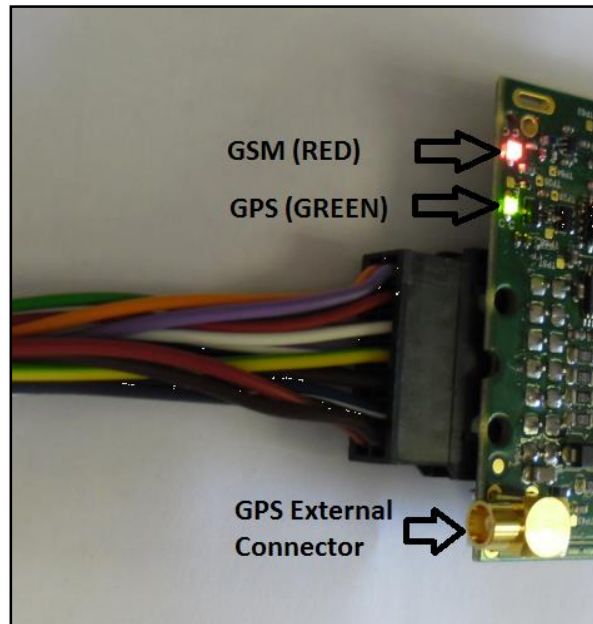

The GREEN LED (closest to the GNSS External Antenna connector) indicates

- GNSS status
- Trip status, in trip or out of trip

The RED LED indicates

- GSM status
- Communication setting status, communication settings received or waiting for settings

### 7.7.1 GNSS LED flash codes (GREEN)

Out of trip (2 second repeat cycle, LED mostly OFF)			
Out of trip with no GNSS lock			GREEN LED: One short ON blip once every two seconds
Out of trip with 2D GNSS lock			GREEN LED: Two short ON blips every two seconds
Out of trip with 3D GNSS lock			GREEN LED: Three short ON blips every two seconds
In trip (1 second repeat cycle, LED mostly ON)			
In trip with no GNSS lock			GREEN LED: Toggles ON/OFF in quick succession continuously
In trip with 2D GNSS lock			GREEN LED: 50% ON and 50% toggling ON/OFF in quick succession every second
In trip and GNSS has acquired 3D lock. The MiX 2000 will subsequently be able to report accurate GNSS points.			GREEN LED: Mostly ON followed by two short OFF blips every second

### 7.7.2 GSM LED flash codes (RED)

No communication settings received (LED mostly ON)			
GSM OFF			RED LED: OFF
GSM ON, searching for network*			RED LED: Mostly ON with some OFF time once every second
SMS only			RED LED: Almost completely ON with one short OFF blip once every two seconds
GPRS ready			RED LED: Almost completely ON with three short OFF blips once every two seconds
GSM Connected			RED LED: Almost completely ON with two short OFF blips once every two seconds
Communication settings received (LED mostly OFF)			
GSM OFF			RED LED: OFF
GSM ON, searching for network			RED LED: Mostly OFF with some ON time once every second
SMS only			RED LED: Almost completely OFF with one short ON blip once every two seconds
GPRS ready			RED LED: Almost completely OFF with three short ON blips once every two seconds
GSM Connected			RED LED: Almost completely OFF with two short ON blips once every two seconds

## 7.8 Starter Interrupt

The MiX 2000 requires an external relay for the interruption of the vehicle's starter circuit. The relay required should be adequately rated for the purpose intended. Please note that a 30A or 40A (contact rating) relay should be selected. A standard 5 PIN automotive relay manufactured by a reputable supplier (e.g. Bosch) would be adequate. The correct relay operating voltage is required; failure to do so will damage the relay. 24V relays will not function correctly in 12V applications and 12V relays will be damaged when used at 24V.



To connect the relay, it only needs to be plugged into the relay socket on the Main Harness. The two 2mm<sup>2</sup> black wires represent the two sides of the relay contacts that are controlled via the driver ID Plug. Cut the wires as short as possible, where higher current will be interrupted via the relay. Also use a cable-tie to secure the relay through the mounting ear (5mm hole) to the main harness, or where possible an M5 lock-nut and bolt is to be used to secure the relay to the vehicle. Ensure that the relay wires have enough play on them not to strain the relay terminal crimps connecting the relay to the wires.

It is not necessary to use a relay with a built in protective diode, because the MiX2000 has built in protection already. **WARNING:** Should a relay with a diode be inserted incorrectly, it will short positive to ground. See simplified connection diagram below:

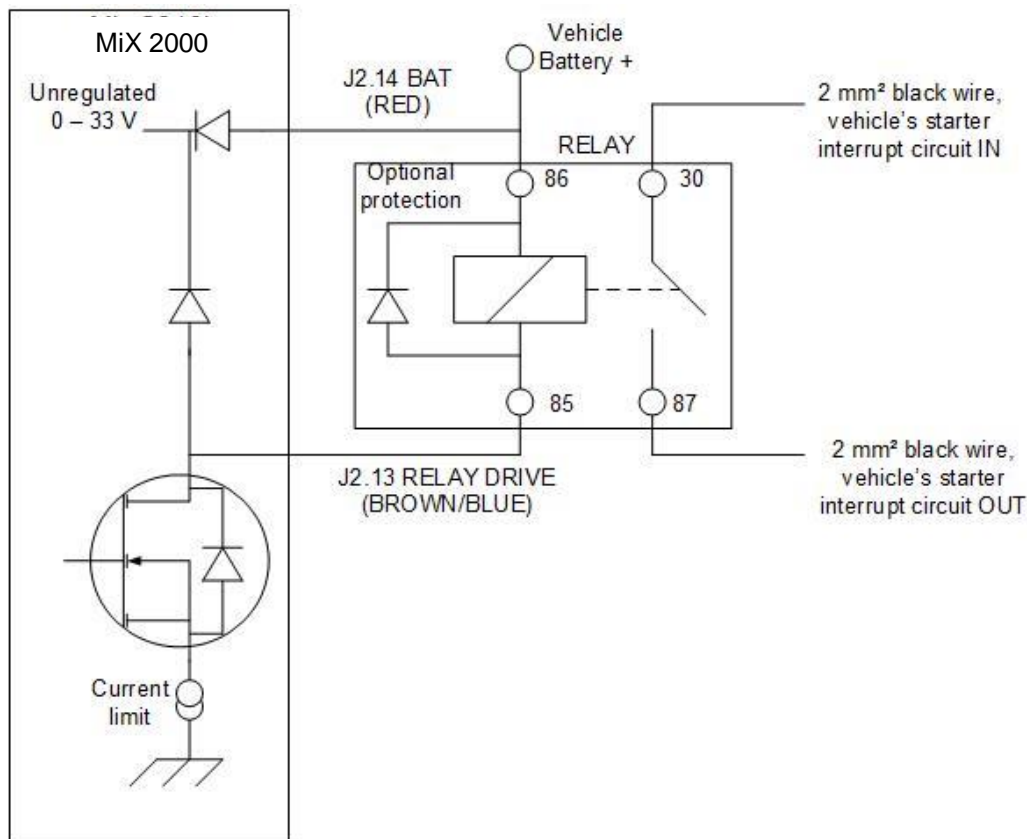

Code Plug Socket Installation

**Note:** Please follow the instructions, regarding the positioning of product components, as contained in the “Safety” section of this document 2.4.4.

- The Code Plug Socket must be installed inside the passenger compartment or the driver cabin, to protect it from possible damage by water or other environmental factors.
- The Code Plug Socket should not be installed in or near the ventilation or heating systems, which may cause damage to it due to overheating.
- The Code Plug Socket should be installed in a position where it will not be subjected to pressure, impact or excessive vibration.
- Select the installation position carefully before proceeding with the installation.
- Mark and drill or cut the required hole. Hole size = 13/16” or 20 mm
- Remove the mounting clip from the socket.
- Remove the protection film from the adhesive surface of the foam ring and press it firmly against the back of the interface.
- Insert the socket into the mounting hole and slide the mounting clip into position.

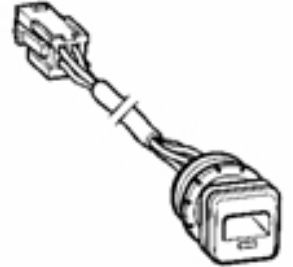

### 7.8.1 Positioning the MiX 2000 Unit in the vehicle

**Note:** Please follow the instructions, regarding the positioning of product components, as contained in the “Safety” section, of this document. 2.4.4

- The MiX 2000 must be installed inside the passenger compartment or the driver cabin, to protect it from possible damage by water, solvents, fuel or other environmental factors.
- The MiX 2000 should not be installed in or near the ventilation, heating system, or hot surfaces which may cause it to overheat or be damaged by condensed water vapour.
- The MiX 2000 should be installed in a position where it will not be subjected to pressure, impact or excessive vibration. Uneven surfaces, where the box can be deformed or damaged should be avoided.
- Select the installation position carefully before proceeding with the installation.
- Mark and drill the required holes.
- Route cables from the unit to the appropriate senders within the vehicle. Additional information can be found in the “Harness Installation” section of this document.

## 7.9 Signal Inputs

### 7.9.1 Digital Inputs

The MiX 2000 is equipped with two digital inputs (I1-I2), which can be used to monitor digital signals. When the voltage threshold is crossed, an event is triggered. The default configuration is set for a threshold of 6V to provide digital input type operation on both 12V and 24 volt systems. Please refer to the “Specifications” and “Harness Installation” sections, of this document, for more details. The external inputs and ignition line are protected from typical vehicle transients and can be directly connected to most vehicle inputs between 0 and 33 V. The input impedance is >100 kΩ. Typical connections are shown below:

Note: There is no internal pull-up resistor in the MiX 2000 so observe the correct wiring configurations shown below for switching to ground or switching to vehicle supply.

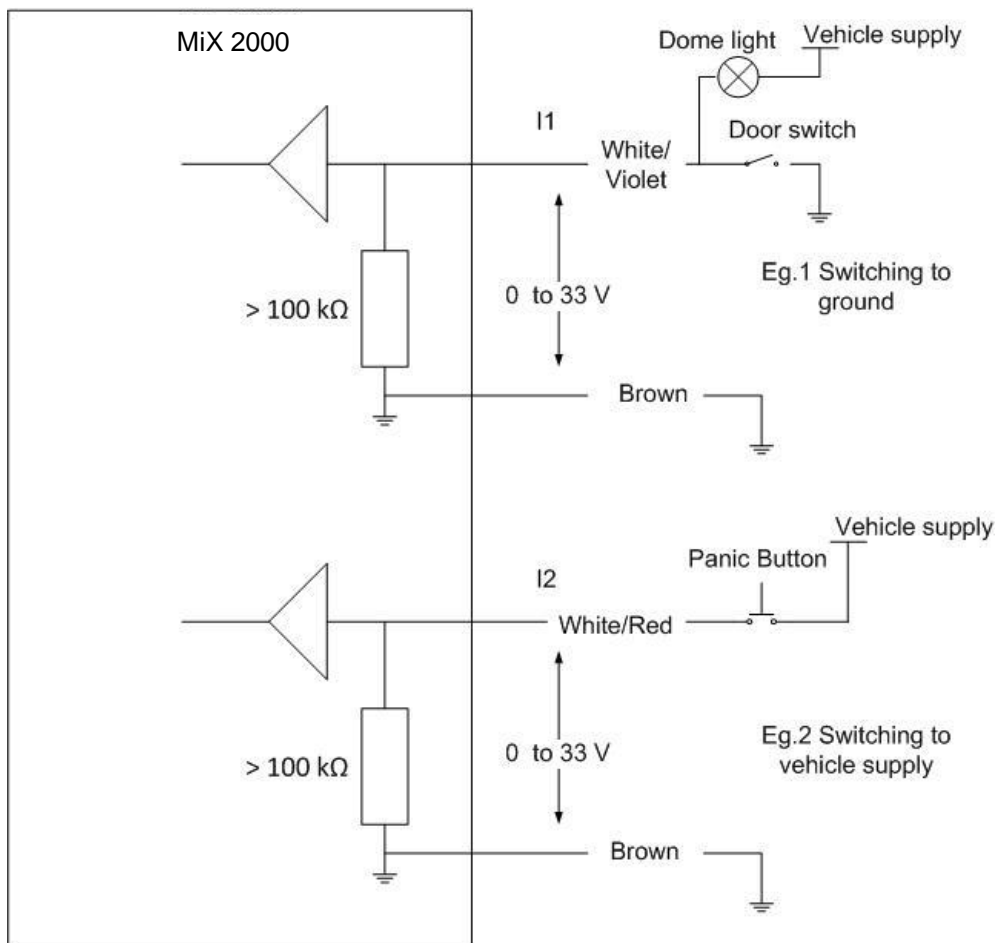

## 7.9.2 Ignition Input

The MiX 2000 includes a dedicated ignition input that must be wired if the starter interrupt immobilizer functionality is required. The input should be connected to the ignition signal on the vehicle. The MiX 2000 will automatically compensate for a 12 or 24V vehicle supply and no configuration is required. For a typical connection, see below:

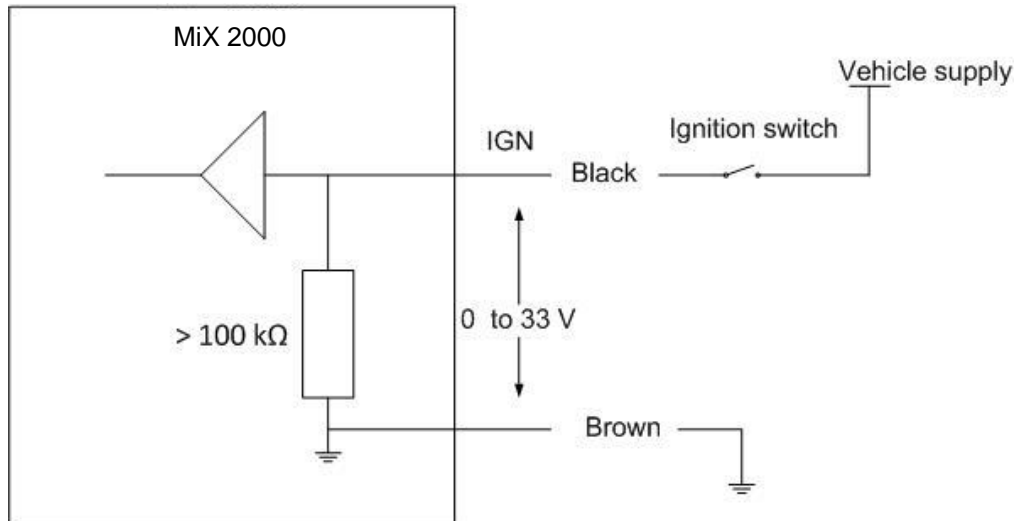

Note: If a minimal install is being performed and the vehicle's ignition wire is not available the MiX 2000 can use its internal accelerometer, GNSS and measurements of the vehicle's power supply to determine trip start and stop conditions. If this configuration is required it is important to configure the unit correctly see 7.12 below. For improved trip start/end plotting accuracy on the MiX Telematics Fleet Manager user interface, it is recommended that the wired ignition configuration be used.

## 7.10 Power Outputs

### 7.10.1 External Relay Drives

The MiX 2000 has one external relay drive output (Relay Drive 1), which is suitable for controlling an external relay.

- This output is controlled by the MiX 2000 and is configured to provide immobilizer functionality when the attached relay is wired to interrupt vehicle starting. The relay is powered when a driver code plug is inserted into the Code Plug Socket and automatically powered down 30seconds after the end of a trip
- The Relay Drive Output connects to the ground side of an external relay.
- The current handling capability of the external relay drive is limited to 200mA.

Please refer to the, Starter Interrupt section 7.8 of this document, for more details.

## 7.11 Serial Communication

The MiX 2000 is equipped with one RS232 external serial port. The 14-wire Fleet Harness (see section 7.5.2) and an additional connector are required to connect to this port. This interface is currently limited to allow serial port configuration of communication settings if the automatic commissioning process fails.

## 7.12 Configuration of unit

The MiX 2000 is configured with default fleet settings during commissioning. Via the MiX Fleet Manager software interface it is possible to make over the air changes to the following settings:

- Odometer – Default 0km

- Over Speed Limit – Default 120 km/h/s
- Harsh braking limit – Default 15 km/h/s
- Harsh Acceleration Limit – Default 10 km/h/s
- External GNSS Antenna Connected – Default No
- Ignition Wired – Default No
- Driver ID Prompt Duration – Default 0 Sec





### 7.13 GNSS antenna connection

The MiX 2000 is fitted with an internal antenna. Fitting or an external antenna is only required when the unit cannot be mounted with a good view of the sky. Mount the GNSS antenna where the least metal (or any conductive) obstruction between the antenna and the satellites will occur. **For best results place the antenna on a metal surface facing towards the sky** (see picture below). The MiX 2000 is also equipped with an internal GNSS antenna so fitting the external antenna is optional. If the external antenna is fitted ensure that the software config for the device matches the install configuration.

Mount as far away from any radio signal or wire bundles as possible.



- Avoid pinching the coaxial cable or bending it sharply (zigzags).
- It would be better to circle/coil excess wires. Take care not to tie coax wires too tight. Using the broadest possible cable tie.
- The best place to circle/coil the wires is about 300 mm in line from the antenna.

<p>Avoid </p>	<p>Recommended </p>
<p>Avoid sharp corners and bends:</p> 	<p>Use rounded bends:</p> 

## 8 Troubleshooting

Supporting Documentation can be found on the [MiX Help Centre](#).



The audible and visual information generated by the MiX 2000 is described in earlier sections of this document.

Symptom	Probable Cause	Action
Unit does not switch ON (LED does not flash)	No battery voltage applied to MiX 2000.	Check the voltage supply to the MiX 2000 Ensure the connectors are properly fitted Check fuse if applicable
GNSS does not get lock	Orientation of the unit is incorrect  Location of unit is limiting good GNSS reception (internal antenna)  Location of the GNSS antenna is limiting good GNSS reception (external antenna)  The GNSS antenna may be plugged in but the software not configured to use it	Mount the unit with the rounded surface facing up, and the label side down.  Install the unit in a location where the GNSS view of the sky is relatively unobstructed by metal or conductive parts  If this is not possible it may be necessary to install the external GNSS antenna  Check the installation of the external GNSS antenna and ensure that the antenna is facing towards the satellites view of the sky is relatively unobstructed by metal or conductive parts  Check that the unit is correctly configured for the antenna type selected. Refer to section 7.12
GSM unable to register on network (see GSM LED flash codes in section 7.7.2)	No SIM card inserted or SIM inserted the wrong way round  Automatic commissioning is not possible on the GSM network selected	Refer to Figure 5 for the correct SIM card orientation. Alternatively replace the SIM card  Use the a serial configuration harness and the Configuration software to manually program ANP and server settings for the unit

## 9 Maintenance

- Maintain the back-up battery for applicable OBCs annually.
- Please ensure that the Code Plug Socket is kept clean and free of dust and dirt. This part is available as an accessory if it needs to be replaced.