

VisionAI (AD Plus 2.0)

Installation and Calibration Guide

Table of Contents

1	Introduction	5
2	Hardware Components	7
2.1.1	Discrete Power Harness option	8
2.1.2	OBDII Power Harness option	9
2.1.3	J1939 Power Harness Option	10
2.2	Components	11
2.3	Required Tools	13
3	System Installation Overview	14
3.1	Important Instructions	14
3.2	Hardware Overview	14
3.3	Hardware Preparation	16
3.3.1	SIM and TF Card	16
3.4	Device Configuration and Calibration	17
3.4.1	Connecting to the Mobile App	17
3.4.2	Connecting to the Internal Web App	19
3.5	Initial Check	21
3.5.1	Checking TF Cards	21
3.5.2	3.5.2 Checking SW version	22
4	Installation	22
4.1	Main unit installation	23
4.1.1	Installation of Window Mount Bracket	25
4.1.2	Installation of Main unit	26
4.2	Connect power supply and ignition signal wires	27
4.2.1	Discrete Wiring connection	28
4.2.2	OBDII 16Pin Wiring connection	29
4.2.3	J1939 9Pin Wiring connection	31
4.3	Driver Camera Installation (Optional)	32
4.3.1	Enabling the new camera on the system	32
4.3.2	Requirements for Installation Position	36
4.3.3	Requirements for Installation Angle	38
4.3.4	4.3.4 Installation Steps	38
4.4	AI Driver Coach (R-Watch) installation (Optional)	41
4.4.1	Wiring Driver Coach	41
4.4.2	Enabling Driver Coach in device settings	42
4.5	Additional AHD Camera installation (Optional)	42
4.6	Checking Communication and GPS Positioning	44
4.6.1	Checking connection with mobile network	44
4.6.2	Checking GPS reception version	45

5	Calibration	45
5.1	Basic Configuration	45
5.1.1	Device Time Setup (Required)	45
5.1.2	APN Setup (If required)	46
5.1.3	Change server address (If required)	48
5.1.4	5.1.4 Speed input selection (if required)	50
5.1.5	Recording settings (Required)	51
5.1.6	Resolution settings	53
5.2	Road Camera Calibration	55
5.3	Driver Camera Calibration (DSC) [AD Plus2.0 Only]	61
5.4	Driver Camera Calibration (DSM – external Camera) – Optional Installation	62
6	MiX Fleet Manager Setup	66
6.1	VisionAI Standalone Setup	66
6.1.1	Enable Standalone Mobile device	66
6.1.2	Make the Peripheral device available	67
6.1.3	Make AI events available on your organization	68
6.1.4	Connecting to the mobile device template (Standalone)	68
6.1.5	Link device serial to your asset	69
6.1.6	Setting Harsh Driving and Overspeed events (standalone)	69
6.2	VisionAI with OBC setup	70
6.2.1	Make the Peripheral device available	70
6.2.2	Make AI events available on your organization	70
6.2.3	Connecting to the mobile device template (OBC)	71
6.2.4	Link device serial to your asset	72
6.3	Record video for OBC events	73
7	Advanced Settings	74
7.1	Standalone settings	74
7.1.1	AVL Rate	75
7.1.2	Harsh Driving Events (Braking/Acceleration/Cornering)	76
7.1.3	Overspeed	78
7.2	Flight Mode	79
7.3	Privacy Mode	80
7.3.1	Function Button Method	82
7.3.2	I/O Line method	82
7.4	SMS commands	83
7.4.1	APN setting change	83
7.4.2	Server Setting change	83
7.4.3	Wi-Fi settings change	84
8	Log Your Work	84
9	Installation Troubleshooting	88
10	Firmware and Configuration upgrade	89

- 10.1 Firmware Upgrade..... 89**
 - 10.1.1 Firmware and Configuration upgrade OTA (optional steps)..... 92
 - 10.1.2 Load FW via USB 92
- 10.2 Load Default Config 92**
- 10.3 APN Setup 93**

1 Introduction

VisionAI (AD Plus 2.0) is an advanced dual dash camera with a built-in AI processor which uses Machine Vision based Video Analytic technology to detect/monitor road events such as un-signalled lane departure, forward collision and following distance (also known as Headway Monitoring Warning - HMW) and unsafe driver behaviour such as fatigue, distraction, smoking, unfastened seatbelt and phone usage. The VisionAI can alert the driver in real-time of dangerous behaviours by triggering a voice warning and audible/visual notifications with the optional AI Driver coach (R-Watch).

The VisionAI will also upload events (and the respective video recordings) to the MiX Fleet Manager platform where they can be reviewed by a fleet manager. They can be used for coaching the drivers, therefore reducing risks and ensuring safe trips. The Device also supports incab recording.

The built in DSC camera detects unfastened Seatbelt, Phone usage and Distraction (looking down). For advanced driver detection features, an external DSM (Driver Status Monitor) camera must be installed. An external side/rear camera can be also installed to provide additional event recordings.

A special variant, designated **AD Plus 2.0-S** has a single camera to detect/monitor road events. No Driver behaviour monitoring, and cabin recording are supported.

The VisionAI (AD Plus 2.0) can be installed alongside a MiX Telematics OBC (FM3xx, MiX4000, MiX6000), or a Teltonika Telematics device. It can be also used as a standalone device.

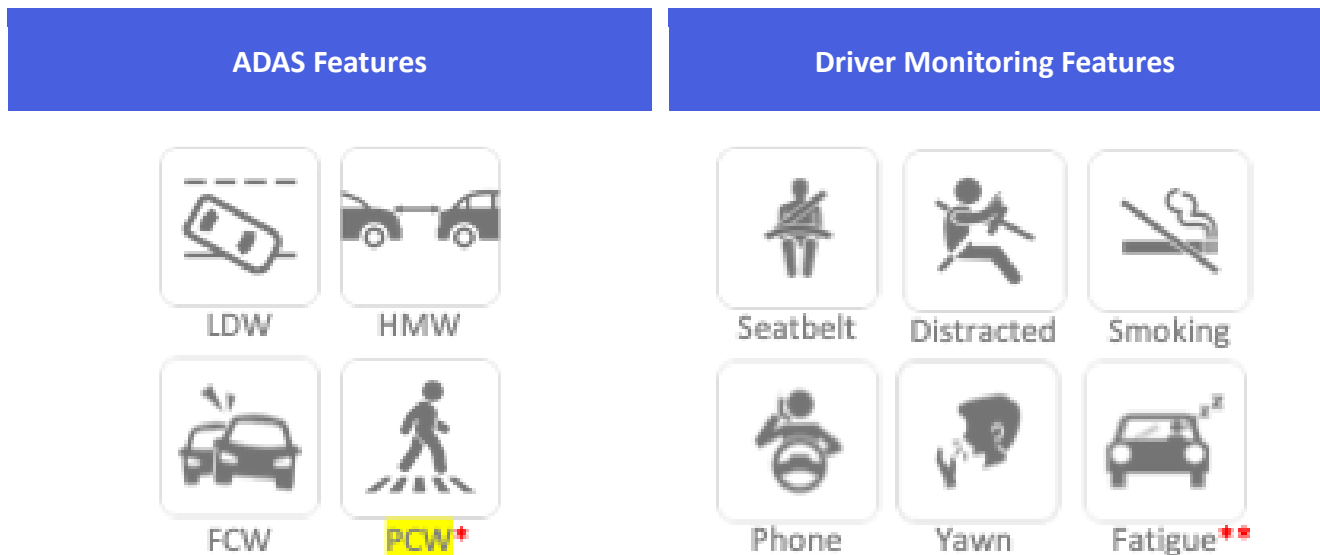

Figure 1: ADAS and Driver Monitoring supported features.

*Beta **Requires additional driver camera



Figure 2: VisionAI (AD Plus 2.0) and AD Plus2.0-S Main Device.



Figure 3: VisionAI Optional Parts

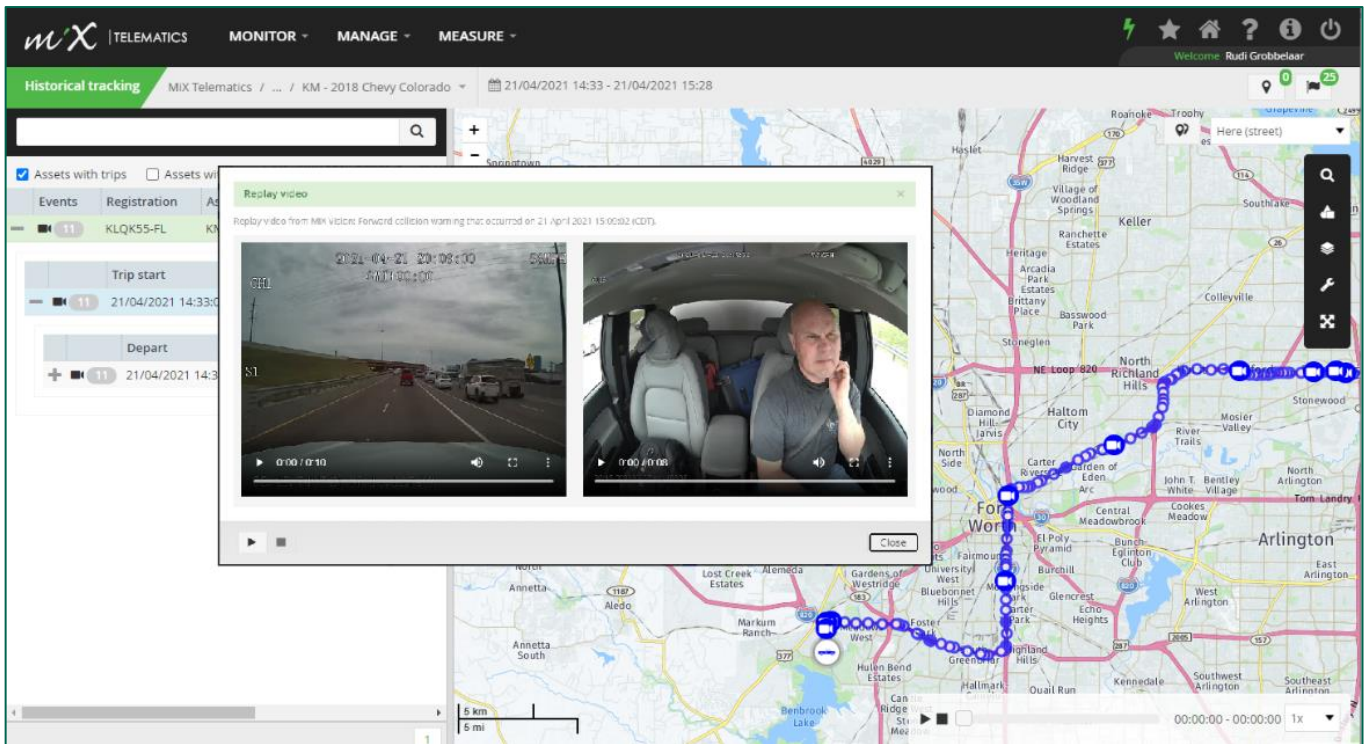

Figure 4: MiX Telematics backend

2 Hardware Components



Figure 5: System Diagram.

The VisionAI can be supplied with three distinct power harnesses, which are connected to the power cable:

- The discrete power cable is designed for direct connection with the vehicle's power supply and CAN wiring.
- The OBD power cable, which has a standard OBD connector, allowing direct connection to the diagnosis port.
- The J1939 cable, which uses a standard 9 pin connector, providing connection to power supply and CAN wiring.

2.1.1 Discrete Power Harness option

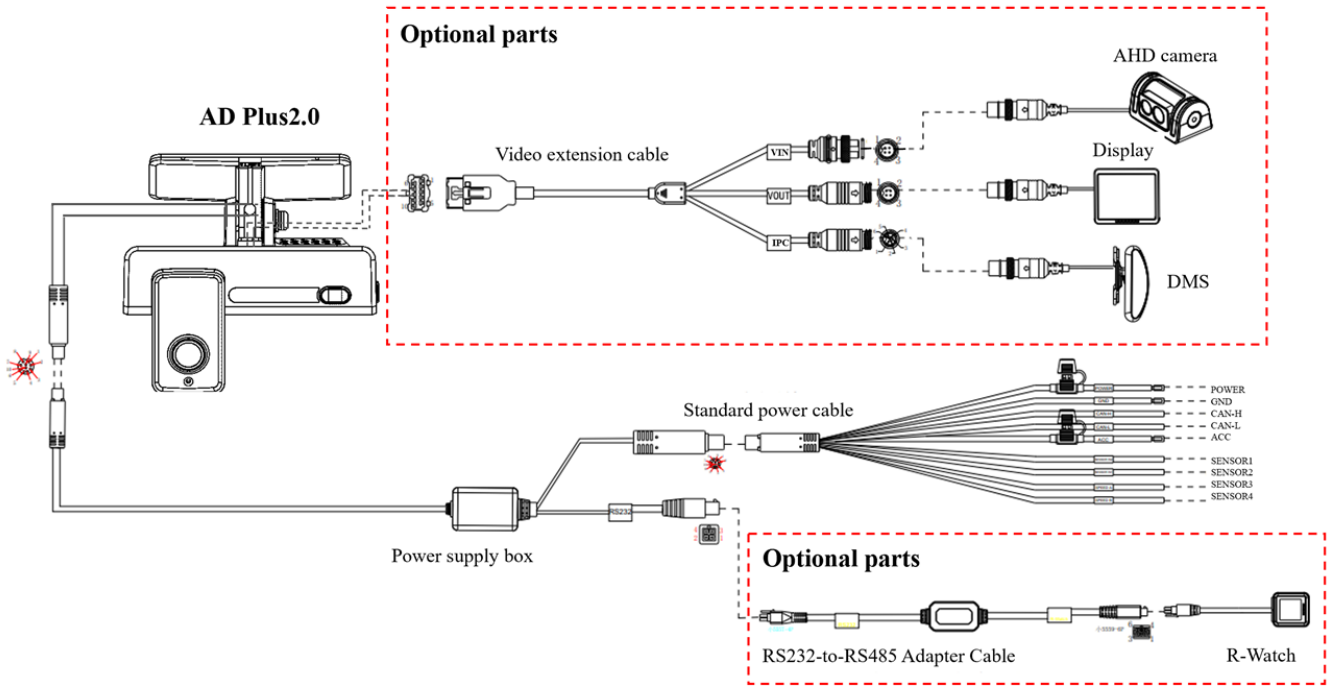

Figure 6: Dual Camera Connection overview – Discrete harness.

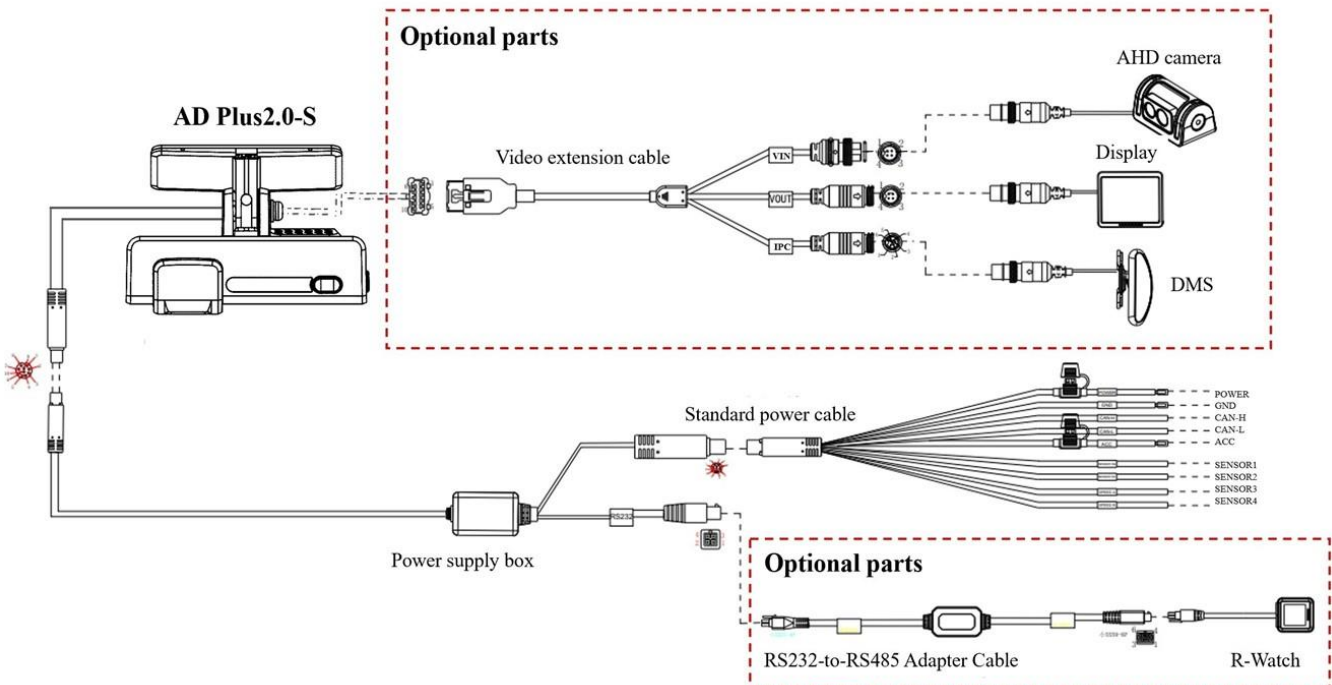

Figure 7: Single Camera Connection overview – Discrete harness

2.1.2 OBDII Power Harness option

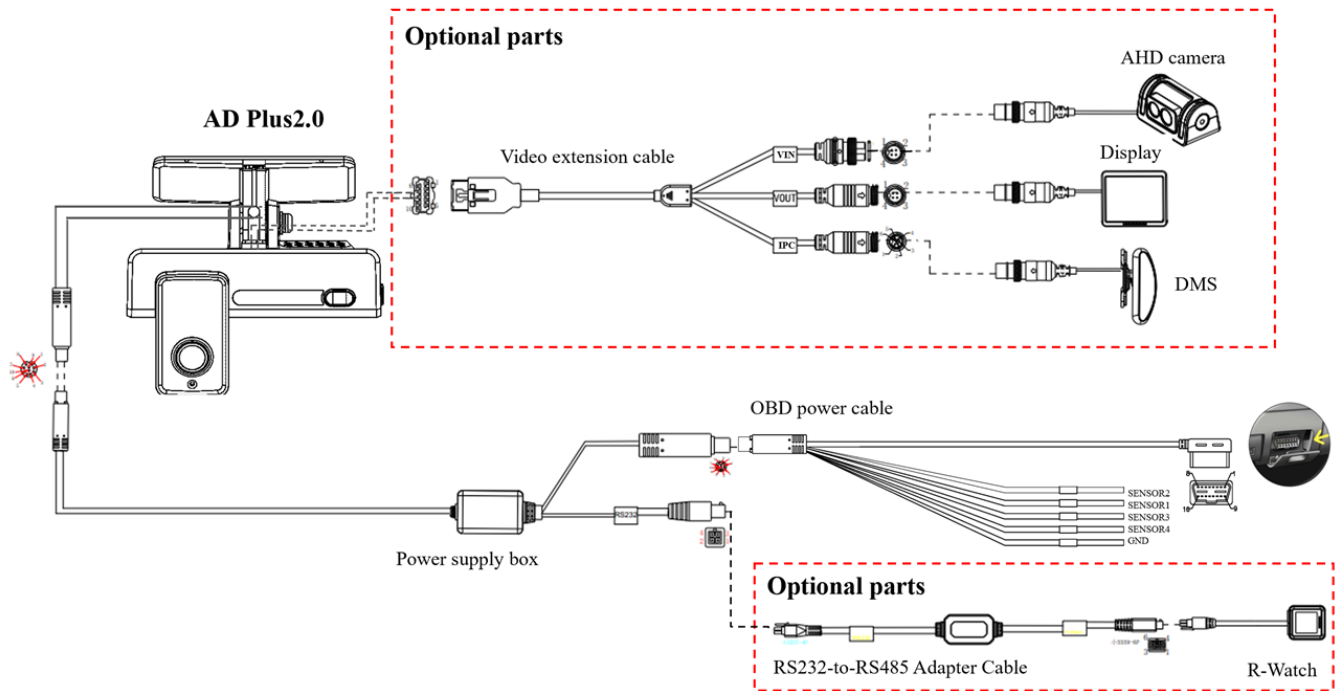

Figure 8: Dual Camera Connection overview – OBDII harness.

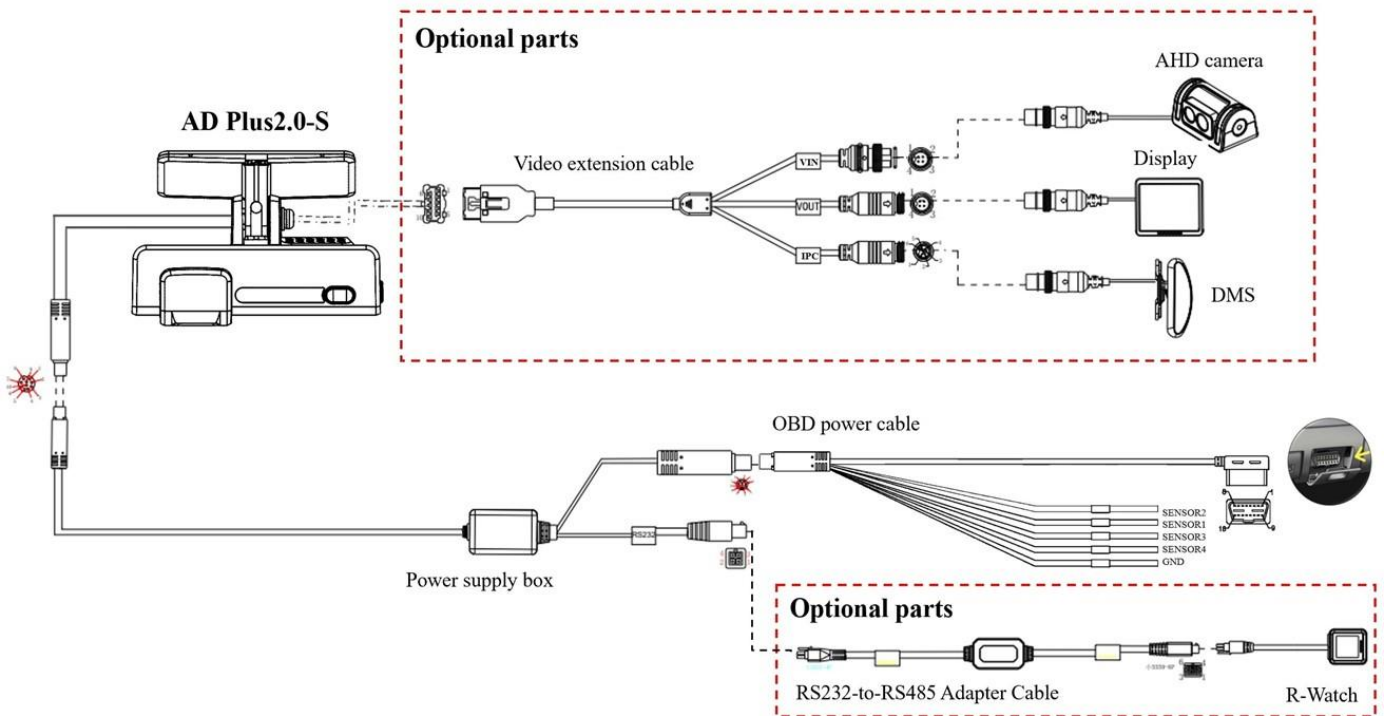

Figure 9: Single Camera Connection overview – OBDII harness.

2.1.3 J1939 Power Harness Option

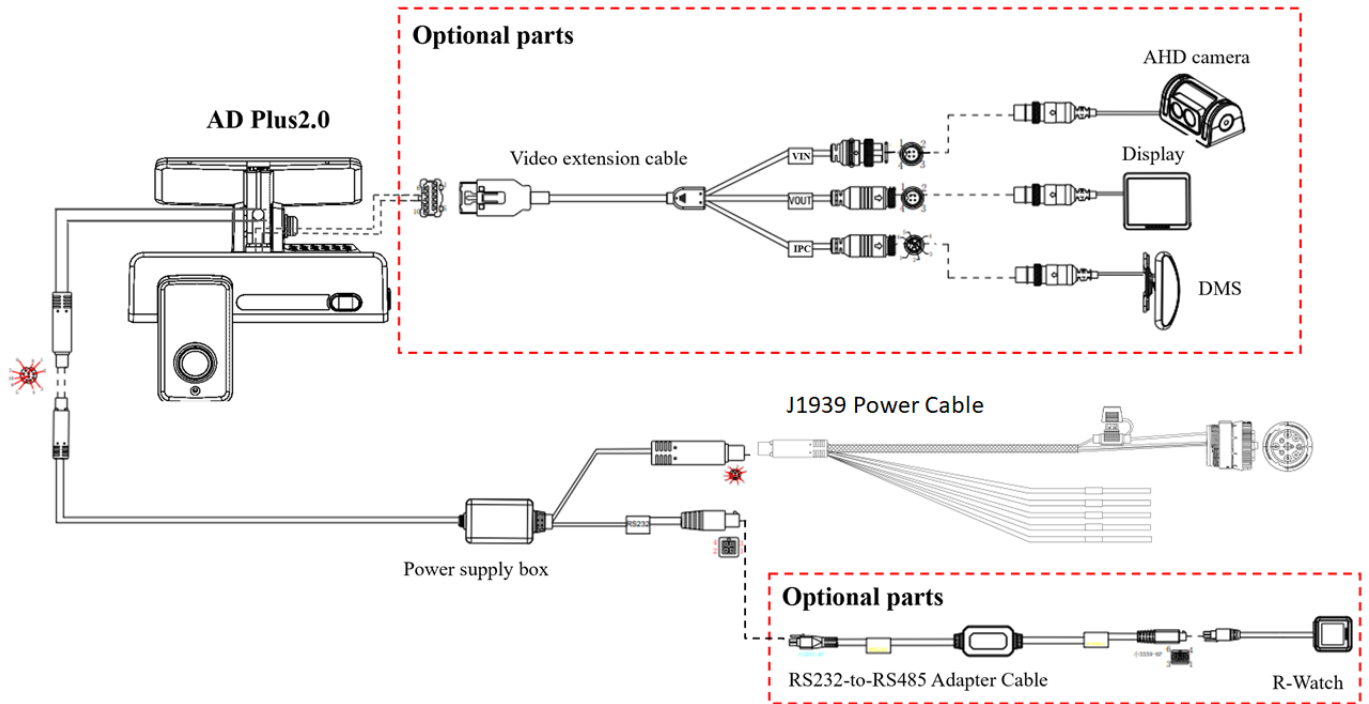

Figure 10: Dual Camera Connection overview - J1939 Cable/.

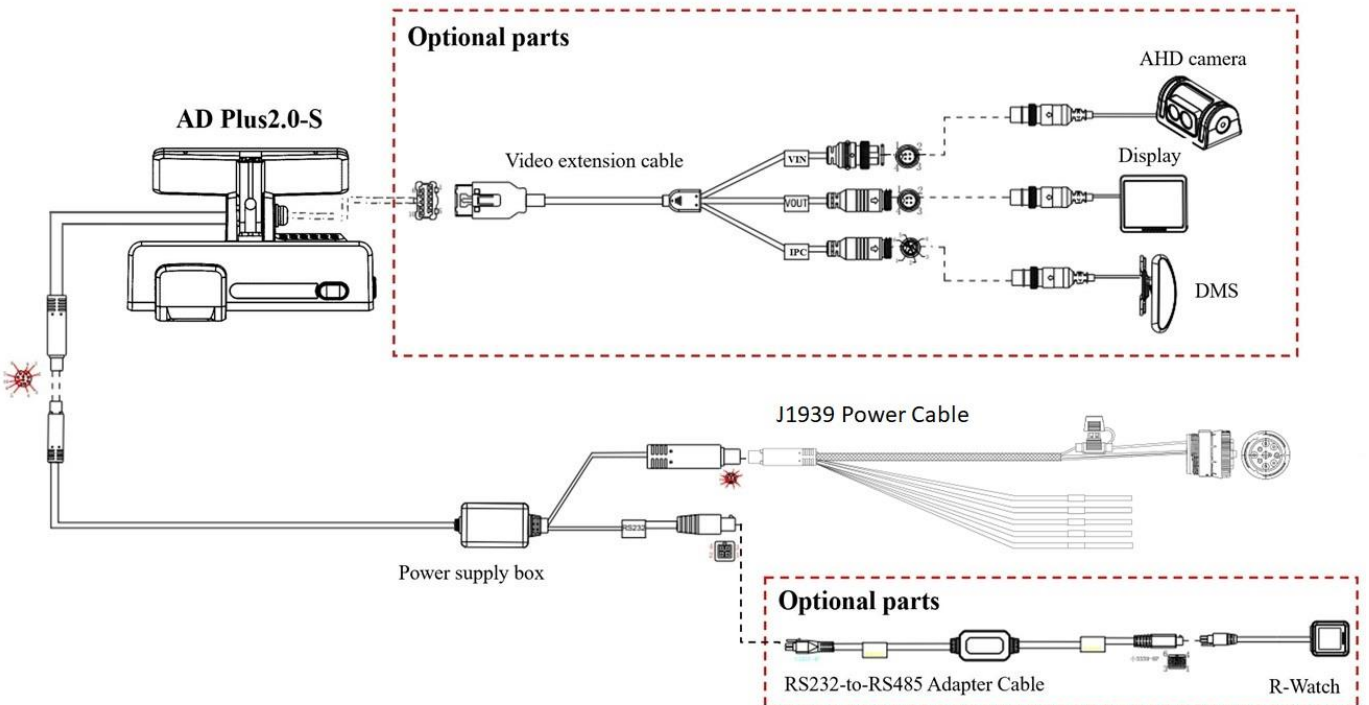

Figure 11: Single Camera Connection overview - J1939 Cable.

2.2 Components

Note that the packing list for different orders can be slightly different and dependent on what you ordered.

No.wipe	Image	Name	Use	Qty.
1		VisionAI (AD Plus 2.0) or AD Plus 2.0-S Main Unit	Video recorder with Road and In-Cab camera (AD Plus 2.0) or Road camera only (AD Plus 2.0-S)	1pc
2		Window Mount Bracket (Main unit)	To mount the main unit to windscreen/shield	1pc
3		Power cable with supply box (3.6m)	Main cable to connect unit to power harness	1pc
4		Power Harness: Discrete	Device Power and I/O *Choose at ordering	1pc
		Power Harness: OBDII – 16Pin		
		Power Harness: J1939 – 9Pin		
5		TF card (max 256 GB)	Data storage	2pcs
6		Nano SIM Card	For network connection. Not installed at factory (see installation section)	1pc
7		Bracket Bolts	Secure Main unit to Window mount bracket	2pcs

No.wipe	Image	Name	Use	Qty.
8		Hex Key	Camera adjustment, TF/SIM card slot cover.	1pc
9		Wipe	Lens/surface cleaning	1pc
10		Prying tool	To hide main cable in lining of vehicle	1pc
11		AI Driver Coach (Optional)	AI Beep and Event Icons	1pc
12		Serial Transfer Cable (Optional)	Required to connect AI Driver Coach	1pc
13		Driver Camera (IPC) (Optional)	Advanced Driver fatigue detection	1pc
14		V-out Cable (Optional)	To connect external cameras to the main unit.	1pc
15		Extra Camera (AHD) (Optional)	To add an additional camera to the installation (rear view and side cameras)	1pc
16		AHD/IPC Extension cables (for the cameras) (Optional)	Required for installing rear and side cameras and DSM Camera (for larger trucks and buses)	1pc

2.3 Required Tools

Commonly Used Installation Tools				
No.	Image	Tool	Use	Qty.
1		Power drill	Drill in screws	1pc
2		Common screwdriver kit	Tighten and adjust the cam	1pc
3		zip tie	Securing wires	Several
4		Marker pen	Marking measurements	1pc
5		wire stripper	Cutting wires	1pc
6		wire pliers	Cutting wires	1pc
7		Waterproof tape	Extension line connection	1pc
8		Electric tape	Securing wires	1pc
9		Multimeter	Vehicle power, pulse signal, voltage testing	1pc

3 System Installation Overview

3.1 Important Instructions

- Before installation, please park the vehicle on a flat surface area and shut down the engine (do not park the vehicle on a ramp or an inclining/declining road).
- Before installation, please observe the vehicle environment and follow the principles below:
 - The installation position and wiring of the product shall neither affect the driver's view nor affect the adjustment of the rear-view mirror and sun visor.
 - The camera lens for monitoring the road condition ahead of the vehicle must be within the working range of the windshield wiper.
 - The installation position of the camera for monitoring the driver in the vehicle shall comply with local regulations.
 - The installation position shall be convenient for the replacement and maintenance of TF and SIM cards.
- The appropriate installation position shall be selected according to the vehicle environment. This document is for reference only.
- The appropriate power supply connection method shall be selected according to the specific OEM requirements. If discrete wire connectors are adopted, connection to the power supply and all signal cables of vehicle is required, and shall be carried out by specialized personnel, as it may be dangerous for non-specialized personnel to operate the vehicle's power system without authorization. This document is for reference only.
- Ensure to take special note of **4.1 Main Unit Installation** and **4.3 Driver Camera Installation**. Any deviation on measurement limits and installation position will result degraded AI performance. Please ensure to capture the installation height and position of installation on your job card.

3.2 Hardware Overview

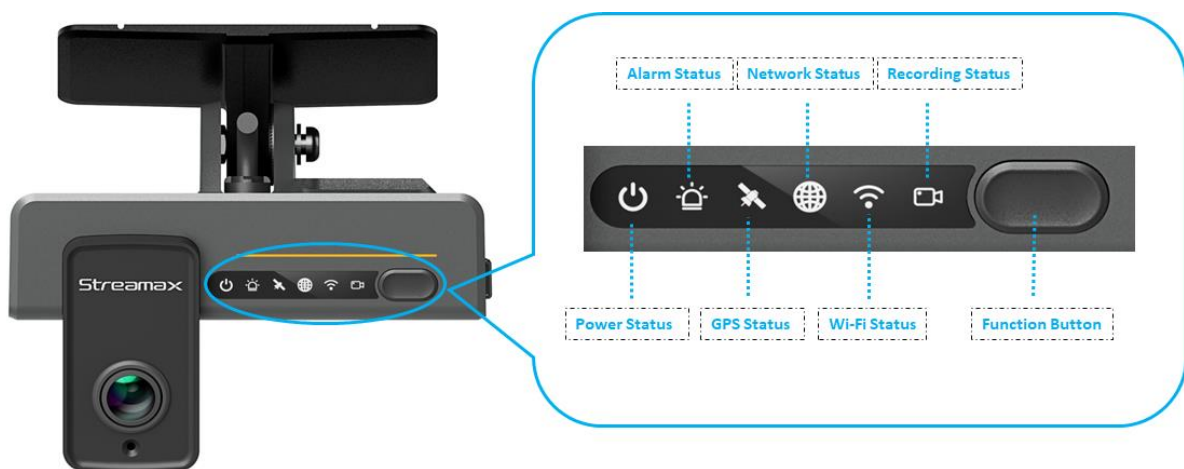

Figure 12: Device functions.

LED State Indicators

Status LED	Icon	State	Description
Power		Off	Device is Powered off
		Green	Device is Powered up
Alarm		Off	No alarms occurred
		Red	Flash 3 times when an alarm occurs
GPS		Off	Normal operation, GPS lock reached
		Red	No lock, module not connected or damaged
Network		Off	Normal operation, device connected to network
		Red	Not connected to server Flashing: Device in Flight mode (all Radio's off)
Wi-Fi		Off	Wi-Fi module not operational
		Green	Device in AP (access point) mode
		Red	Problem with Wi-Fi module
Recording		Off	Normal operation, all cameras recording
		Red	One or more cameras stopped recording or in Privacy mode

Function Button

- Emergency Alarm: Pressing once for less than 2 seconds generates an emergency alarm. (If enabled in configuration)
- Privacy Mode Protection: Pressing once for more than 2 seconds turns on the privacy mode (stop video/audio recording). Pressing it again for more than 2 seconds turns the privacy mode off. (If enabled in configuration)
- Switch Wi-Fi status: Pressing the twice within 2 seconds will switch the device Wi-Fi to AP mode if not already in that mode.

3.3 Hardware Preparation

With the main unit powered down, remove the side cover to install the TF card(s) and the SIM card. Use the L-shaped Hex key (provided with the device) to open the panel, by loosening the screw counter clockwise.



Figure 13: Main unit preparation.

3.3.1 SIM and TF Card

A Nano SIM (4FF) Card is required for the VisionAI.

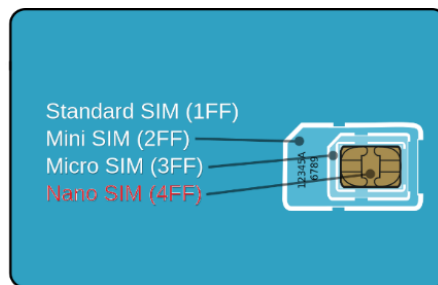

Figure 14: Size of the required SIM Card.

The main unit side view below indicates the orientation and position of the SIM and TF cards.

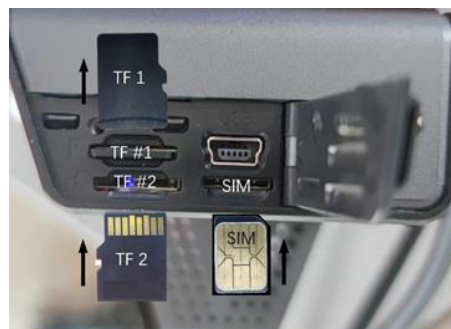

Figure 15: Bottom View: SD and SIM card slot.

Securing the SIM and TF cards panel shall be only done during the calibration step as it must be opened to allow the adjustment of the internal camera.

After installing the SIM and TF cards, remove the lens protection stickers on the front and rear lenses and the protective film on the LED light front panel.



Figure 16: Removing protective stickers and film

3.4 Device Configuration and Calibration

The VisionAI can be locally configured using an Internal Web based Application or a mobile app.

Most of the configuration steps can be performed using both tools, however some steps are more easily performed using one of them.

3.4.1 Connecting to the Mobile App

Installing the Veyes App

The “Veyes” app can be used for configuration and calibration. To download the app, scan the QR Code below.



IOS (Apple)



Android (Google)

Figure 17: QR Codes to download the Veyes APP.

Connecting with the VisionAI

The connection between the device and the mobile phone is performed through Wi-Fi.

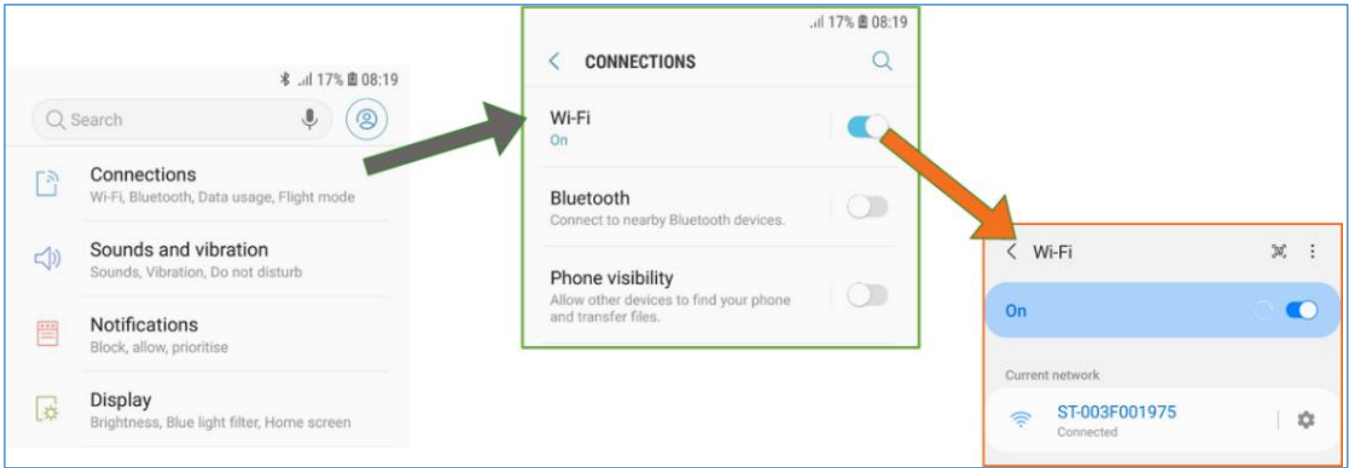

Figure 18: Connecting to the main unit's Wi-Fi hotspot

NOTE: By default, the access point name of an unit is ST_XXXXXXXXX where XXXXXXXX is the device's serial number (example: ST-00DF001975).

1. Launch the app on your mobile, Enter the username and password and press **Login**. Two user levels are available:
 - a. Admin Level (full access): **admin / admin**
 - b. User Level (calibration only): **user / user**

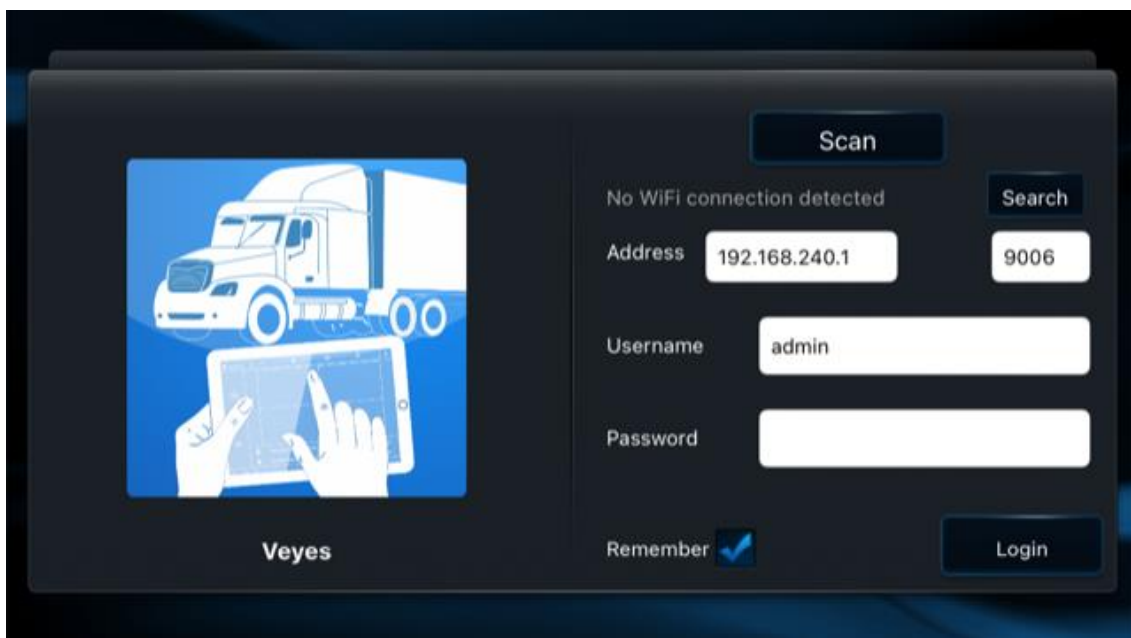

Figure 19: Veyes login interface

The following picture show the typical Veyes app starting window.

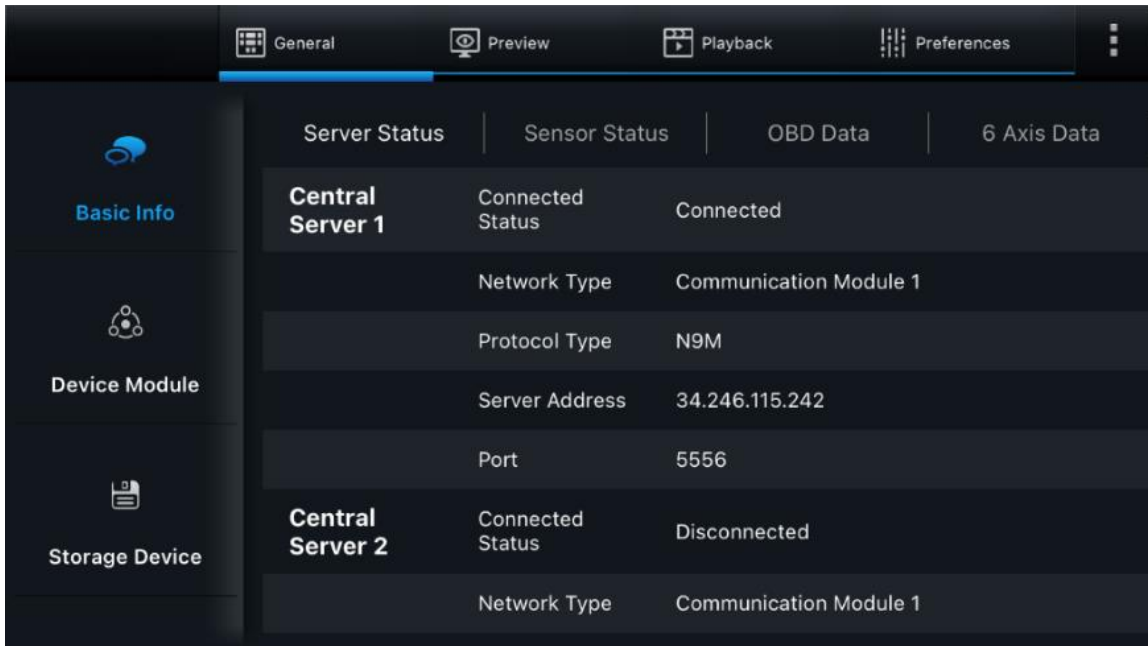

Figure 20: Veyes App starting page

Section	Function
General	Status of all the modules and settings
Preview	Preview of connected cameras and calibration procedures
Playback	Visualization of stored recordings
Preferences	Device settings
Menu [...]	About/ Acceptance mode/ Share log/ Logout

3.4.2 Connecting to the Internal Web App

It is possible to use a mobile phone or a notebook to connect to the internal Web page application

Connecting with the VisionAI

Select the correct Wi-Fi Access Point.

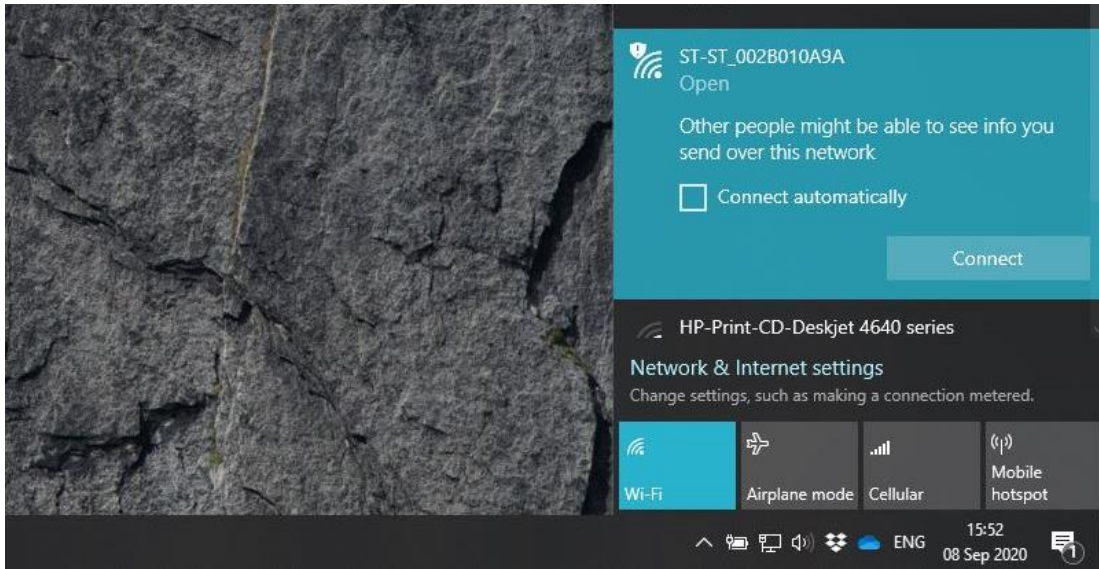

Figure 21: Selecting the VisionAI hotspot.

NOTE: By default, the unit access point name is ST_XXXXXXXXX where XXXXXXXX is the serial number (example: ST-00DF001975).

On any web browser go to the URL: <http://192.168.240.1/login/default.html>. For configuration purposes it is necessary to log in as the administrator.

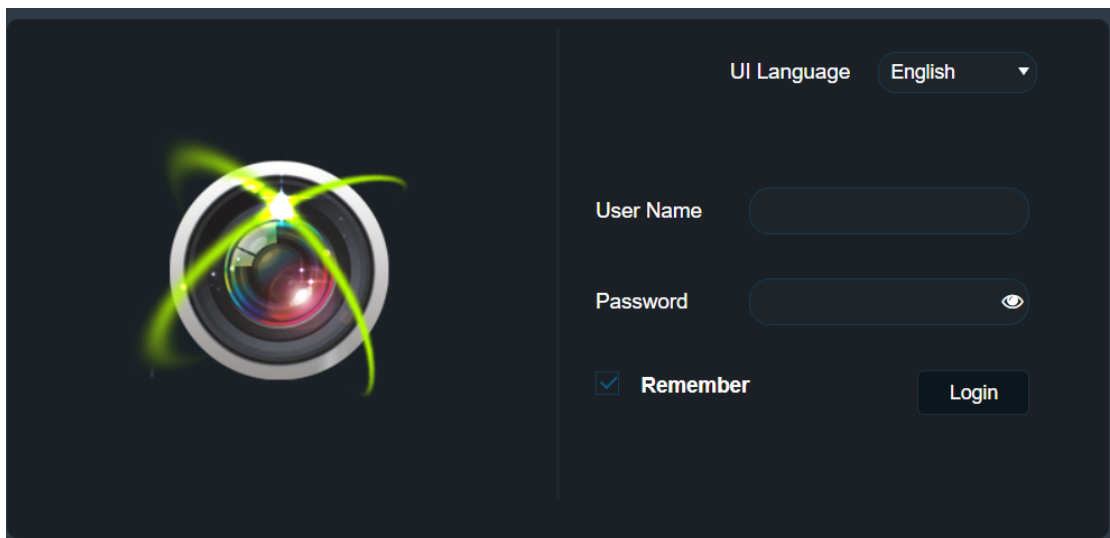

Figure 22: Login into the internal configuration tool.

Please use username/password: **admin/admin**

The figure below shows the starting page of the Web app.

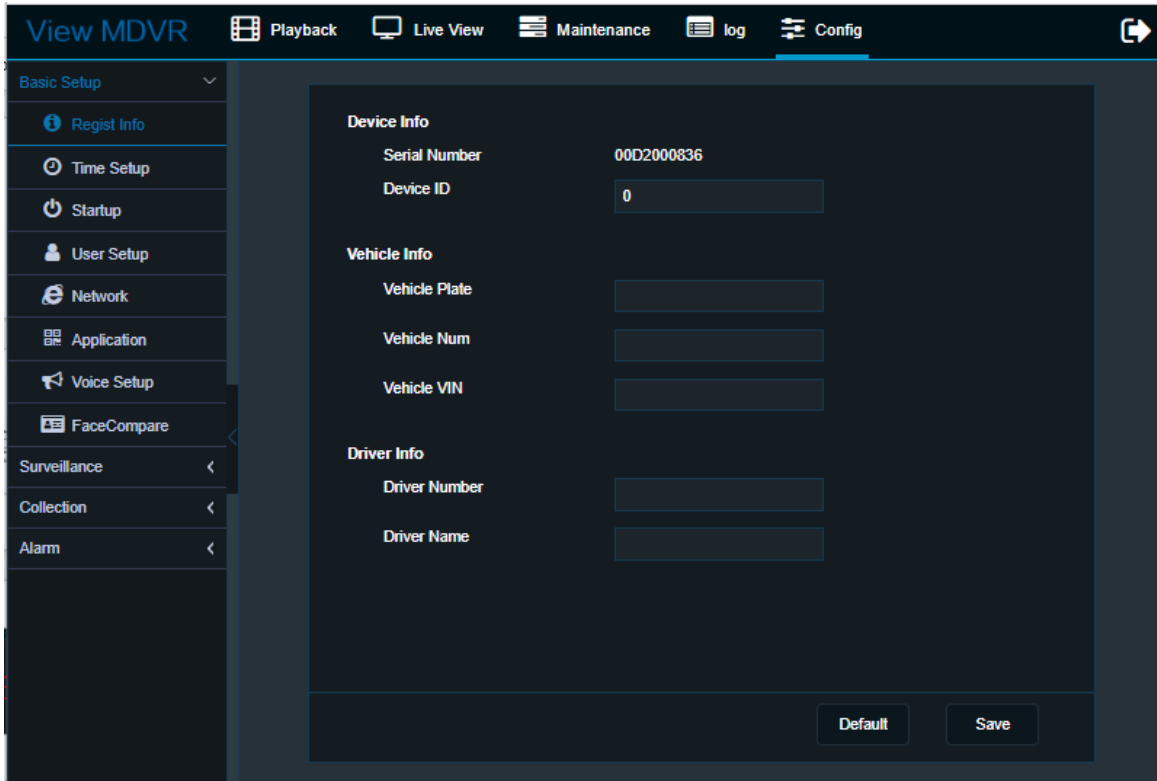

Figure 23: Web app starting page.

3.5 Initial Check

Before installing the device, we recommend running a set of verification steps. Before running them, please connect all cameras and peripherals to the main unit and turn it ON.

3.5.1 Checking TF Cards

Using the Veyes App or the Web App, check if both TF Cards are detected by the device. On the Web App, go to **Maintenance > Storage Device** and check if both cards are shown (see below).

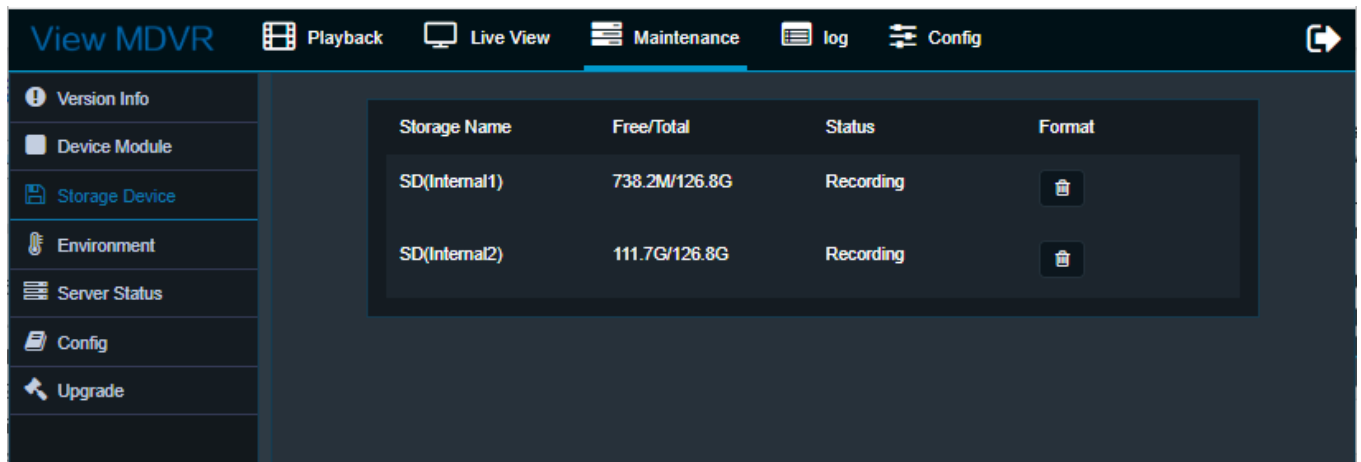

Figure 24: Checking the TF Cards.

See the troubleshooting section if one or both cards are not listed.

3.5.2 3.5.2 Checking SW version

Verify if the SW version set installed in the device is the recommended for your application.

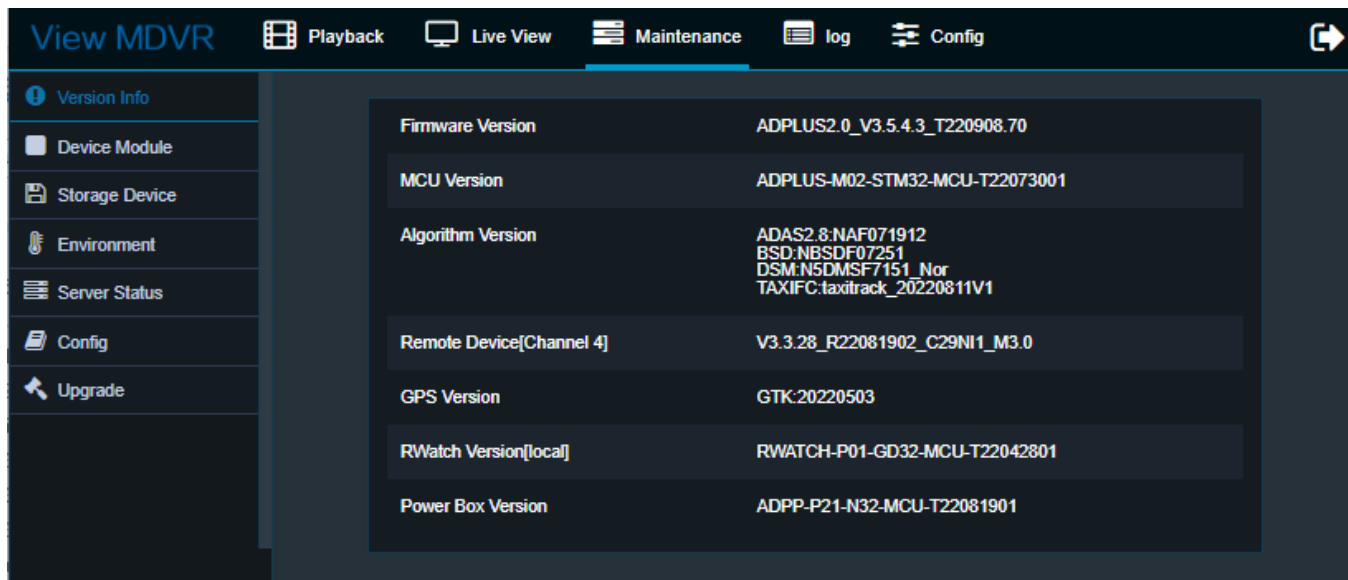

Figure 25: Checking the installed SW versions.

If the installed versions are not the recommended, please contact the MiX representative.

See the troubleshooting section if the R-Watch or external DSM Camera are connected to the main unit, but no SW version is listed (the DSM Camera software is identified as Remote device [Channel 4]).

4 Installation

The installation locations are indicated on the image below.

The main unit is mounted on the top centre of the windscreen/shield. If the optional DSM Driver camera is required, it shall be mounted on the A-pillar next to the driver, or equivalent vertical position on the windscreen/shield.

The Driver Coach should be mounted in easy view of the driver and can be mounted on the windscreen as well. The external camera has multiple installation options.



- 1 DMS CAMERA*
Monitor driver behavior
- 2 R-Watch*
Audio and visual alert
- 3 HD Display*
Blind spot video feed
- 4 AD Plus2.0
Dual channel dashcam with built-in AI
- 5 Rearview CAMERA*
Vehicle rear monitoring

*Optional: 1 2 3 5

Figure 26: Usual installation locations.

Please Comply with 4.1 & 4.3.2 - Above picture (26) is for illustration only

4.1 Main unit installation

Requirements for AD Plus 2.0 installation :

IMPORTANT

1. The main unit must be installed in the middle of the front windshield, generally in the rear-view mirror area at the vehicle's centreline.
2. If this is not possible, the leftward or rightward deviation of the installation position **shall not exceed 5cm** (the leftward or rightward deviation of the unit relative to the centreline of the front windshield is calculated with the centreline of the forward-facing camera lens as a guide).
3. The frontal camera (ADAS) lens must be located within the working range of the left and right windshield wipers (make sure that the screen of the external camera lens is clean and free from stains).
4. The **optimal vertical height** of the main unit's external camera lens to the ground shall be **between 130 cm and 240 cm**.
5. **Do not deviate** from the measurements of Point 2 & 4. If unit is placed outside the recommended measurements please indicate on the Job card and raise a Support Ticket with heading – Vison AI outside recommended measurement.
6. Accurately record all measurements and exact placement of both Main unit and DMS camera

The installation position shall be determined in such a way that the main unit will not hinder the driver from viewing the front blind spot reflector, and there is no obstruction (such as interior rear-view mirror or glass coating) within the field of view in front of and around the internal and external cameras lens.

The installation area is generally selected as shown in the figures below:

Vehicle centerline



Figure 27: Vehicle centreline.



Figure 28: Main unit installation position.

4.1.1 Installation of Window Mount Bracket

Clean the interior and exterior of the glass in the installation area with alcohol cotton to ensure that no dirt on the glass in this area will affect the view of the external camera lens, and ensure the glass is dry.

IMPORTANT - Please comply with 4.1

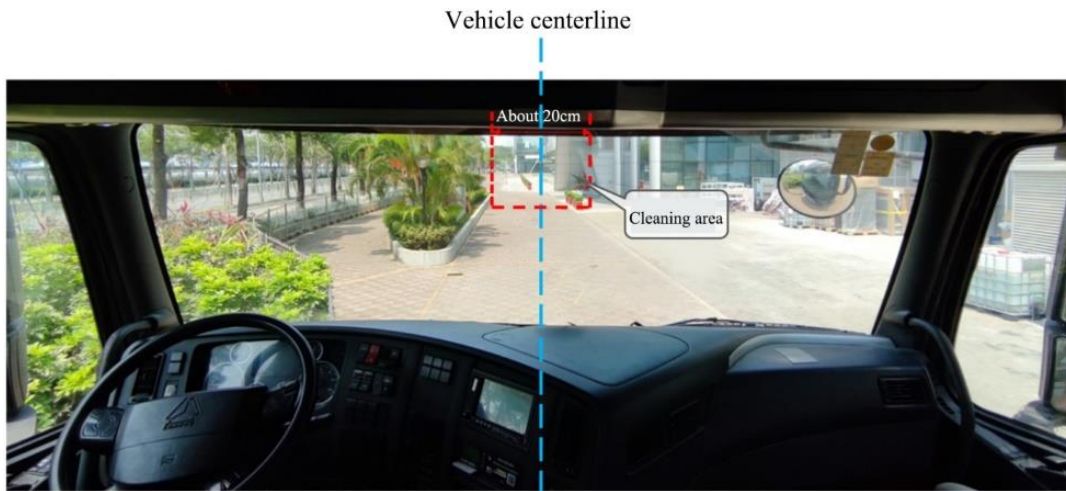

Figure 29: Cleaning area.

- Tear off the 3M adhesive film on the bracket to stick the bracket horizontally on the front windshield with the level as reference, and then press the bracket for 10s to ensure no bubbles between the bracket and the glass.

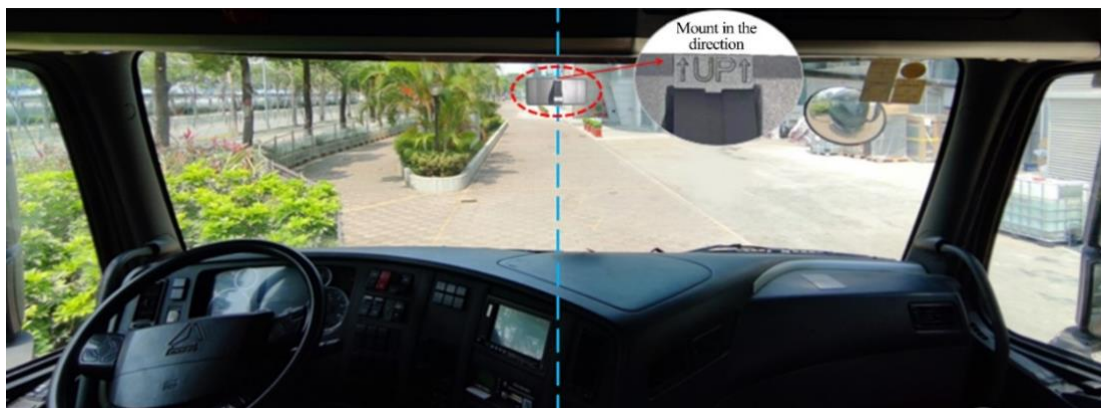

Figure 30: Fixing the bracket.

Note: When installing the bracket, do it according to the direction indicated on it, so that the toothed side faces to the right.

- If the vehicle has wiper blades in the middle of the windshield, the ADAS camera can be installed within the working area of left and right wipers, ensuring the ADAS camera (especially the lens) are cleaned by the wipers in rainy weather.

4.1.2 Installation of Main unit

- Connect the main unit to the bracket with the front side facing inward (with the teeth on the left side of the bracket engaged with those on the left inner side of the unit). Adjust the unit to be levelled vertically.



Figure 31: attaching the main unit to the bracket.

- Once levelled, tighten the bracket stud clockwise with a PH2 cross screwdriver to ensure that the angle of the main unit will not be changed easily.



Figure 32: fixing the main unit to the bracket.

- When fixing, ensure that the cockpit camera screen meets the following conditions:
 - The centre of the cockpit shall be in the middle of the screen.
 - The cockpit screen shall be horizontal.
 - The vehicle's steering wheel shall be visible at the lower left/right corner of the screen.

The cockpit rendering after the lens is properly adjusted is as follows:



Figure 33: Proper view of the Cockpit.

NOTE: Make sure that the connection between the bracket and the main unit is secured so that it will not shake easily. Otherwise, the GPS positioning will be inaccurate.

4.2 Connect power supply and ignition signal wires

Installation of the wiring is dependent on which power harness has been ordered. There are three options, Discrete Wire, OBDII (16Pin) and J1939 (9Pin). The figure below shows where the harnesses are connected to the power cable

The figure below indicates the path of the power cable and the common locations for connecting the harness to the vehicle (Powers wires, ignition, sensors and CAN lines).



Figure 34: Locations for the vehicle's connections.

4.2.1 Discrete Wiring connection

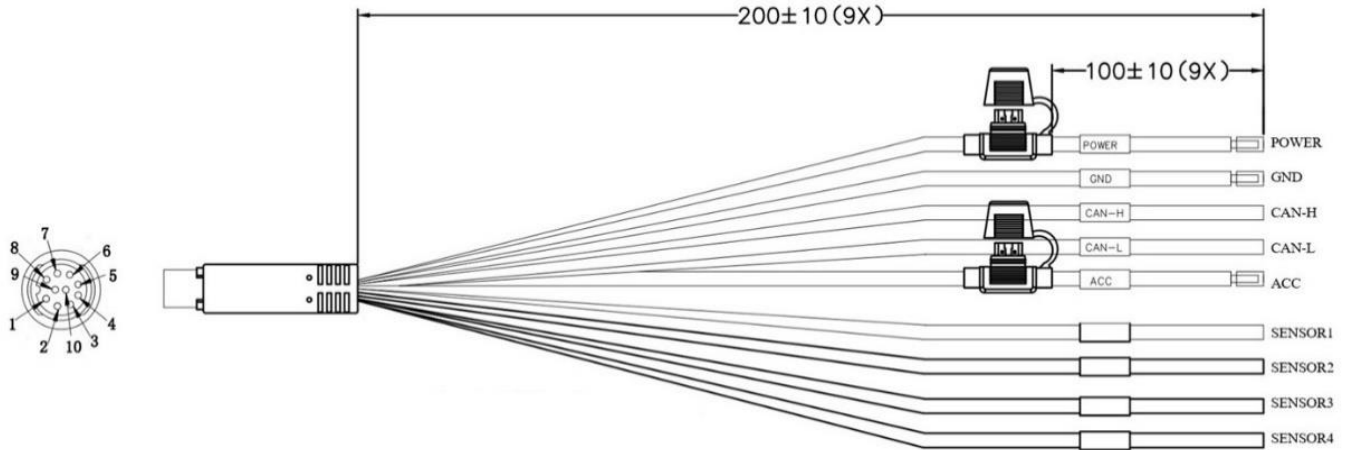

Figure 35: Power Harness: Discrete

Colour	Label	Description
RED	POWER	Vehicle Power Supply (9-36VDC)
BLACK	GND	Chassis Ground
GREEN	CAN-L	CAN Low
YELLOW	CAN-H	CAN High
ORANGE	ACC	Ignition Line
GRAY	SENSOR IN1	Input sensor line
GREEN/YELLOW	SENSOR IN2	Input sensor line
BLUE	SENSOR IN3	Input sensor line
GREEN/BLACK	SENSOR IN4	Input sensor line

- Connect the ACC line on the 9-wire power harness with the vehicle ignition signal line.

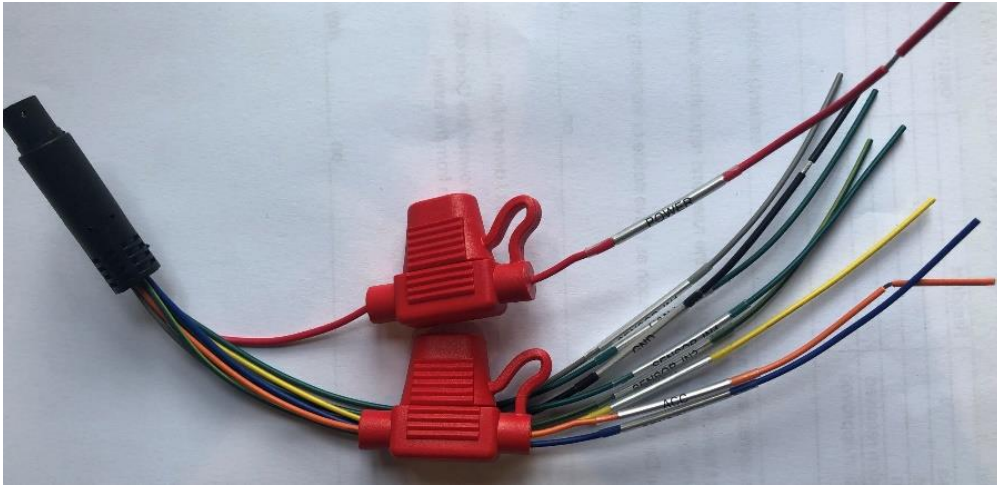

Figure 35: Power Harness: Discrete

Important:

- Before connecting the ACC cable to the ignition wire, make sure that the vehicle is turned off.
- The power wires (POWER and GND) should be directly connected to the vehicle battery.
- Attention: The power wires are still 9-36V after the vehicle is turned off
- The sensor lines are usually connected with vehicle's signals like left steering, right steering and brake.

NOTE: If the signal at vehicle's left steering/right steering/brake lines is a pulse signal, the source of signals shall be set as pulse on the main unit's setting interface. If the measured signal is a continuous high- or low-level signal, the source of the signal shall be set as level.

4.2.2 ODBII 16Pin Wiring connection

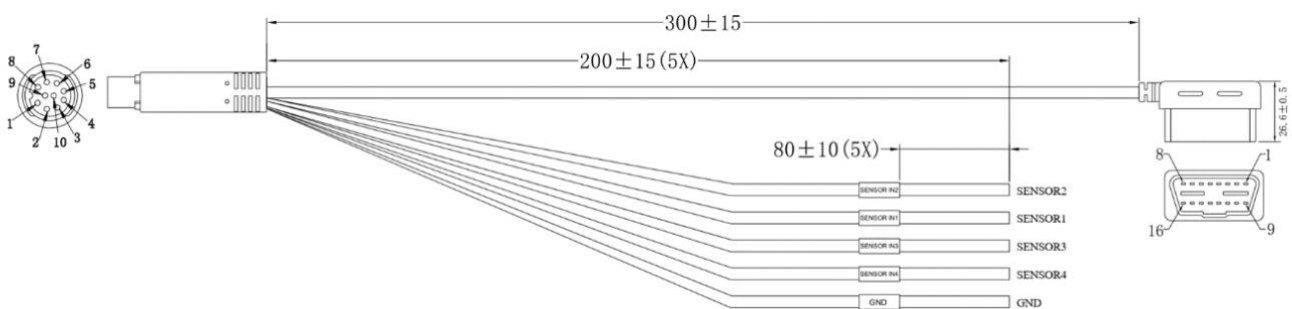
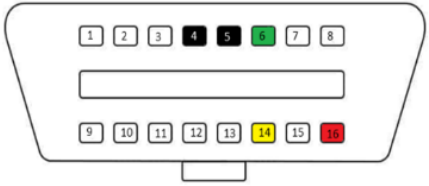

Figure 37: Power Harness: ODBII - 16 Pin.

Colour	Label	Description
GRAY	SENSOR IN1	Input sensor line
BLUE	SENSOR IN2	Input sensor line
GREEN/YELLOW	SENSOR IN3	Input sensor line
GREEN/BLACK	SENSOR IN4	Input sensor line
BLACK	GND (-)	Chassis Ground

Colour	Pin #	Description	OBDDII Connection
BLACK	4 & 5	Vehicle Ground	
RED	16	Vehicle Power	
YELLOW	14	CAN-L	
GREEN	6	CAN-H	

NOTE: When connecting using the 16 Pin OBDII connector, the device detects Ignition via voltage increase on the Power and GND wires.

Locate the vehicle’s OBD interface and directly connect with it.



Figure 38: Connecting to the OBD port.

If Left/Right turning signal usage is required, Sensor Input Lines shall be wired direct to the signal lines. Indicator detection is not possible via OBDII connection.

NOTE: If the signal at vehicle’s left steering/right steering/brake lines is a pulse signal, the source of signal shall be set as pulse on the setting interface of the main unit; if the measured signal is a continuous high- or low-level signal, the source of the signal shall be set as level.

4.2.3 J1939 9Pin Wiring connection

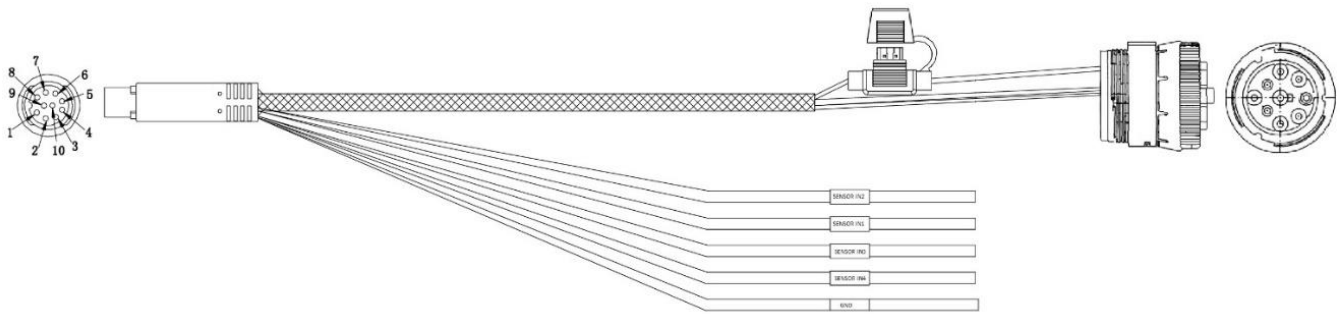

Figure 39: Power Harness: J1939 – 9Pin.

Colour	Label	Description
GRAY	SENSOR IN1	Input sensor line
BLUE	SENSOR IN2	Input sensor line
GREEN/YELLOW	SENSOR IN3	Input sensor line
GREEN/BLACK	SENSOR IN4	Input sensor line
BLACK	GND (-)	Chassis Ground

Colour	Label	Description	J1939 Connection
BLACK	A	Vehicle Ground	
RED	B	Vehicle Power	
GREEN	C	CAN-H	
YELLOW	D	CAN-L	

NOTES:

- When connecting using the 9 Pin J1939 connector, the device detects Ignition via voltage increase on the Power and GND wires.
- If Left/Right turning signal usage is required, Sensor Input lines need to be wired directly to the signal lines. Indicator detection is not possible via J1939 connection.
- If the measured signal at vehicle's left steering/right steering/brake lines is a pulse signal, the source of signals shall be set as pulse on the setting interface of the main unit; if the measured signal is a continuous high- or low-level signal, the source of the signal shall be set as level.

4.3 Driver Camera Installation (Optional)

Install the optional Driver Camera (DSM) in place according to the system installation diagram.

***NOTE:** When adding external DSM camera, it is necessary to disable the onboard driver camera for Driver behaviour events (IA). Refer to Calibration section on how to do this.

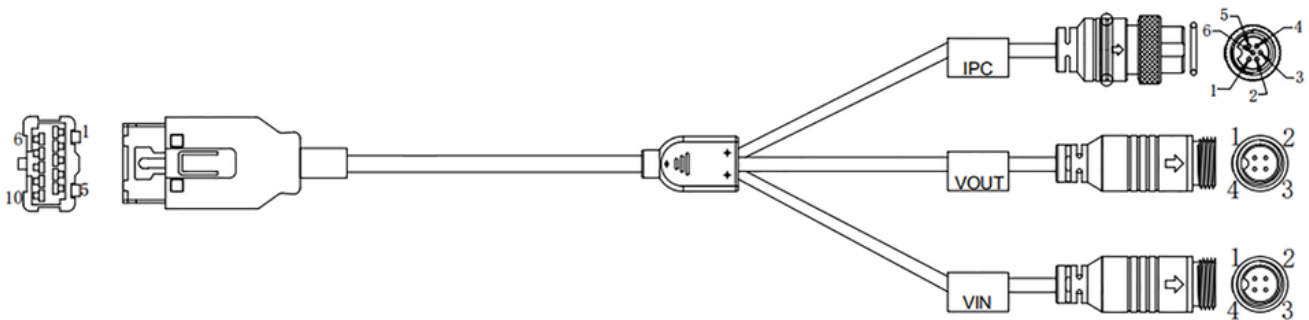

Figure 40: External camera harness.

Label	Channel	Description
IPC	4	Driver Camera (IPC) for enhanced fatigue
VOUT	-	<i>Not used (for video display)</i>
VIN	3	For additional AHD type Camera

4.3.1 Enabling the new camera on the system

By default, only the road and In-Cab (DSC) cameras are enabled to be used on the device. If the external DSM camera is connected, it is necessary to enable the channel and set the Main and Sub Stream settings, otherwise no recording will occur.

4.3.1.1 Enable recording on Channel

Navigate to **Config > Surveillance > Record > General** and enable **Channel 4**

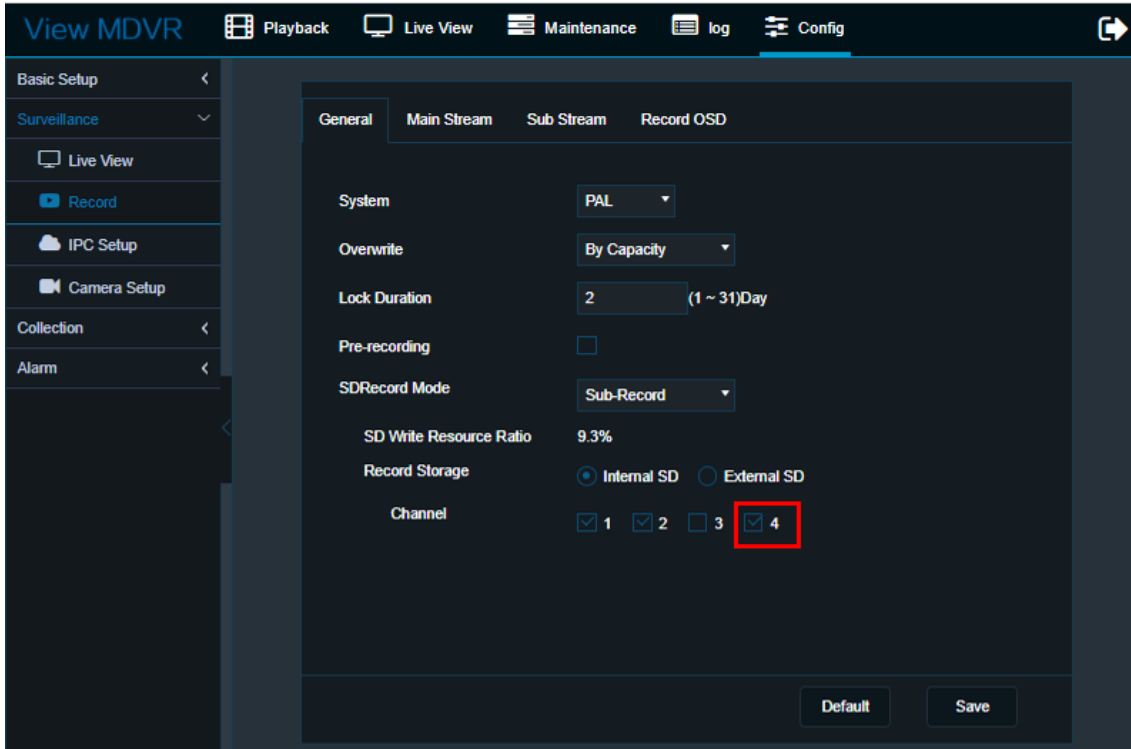

Figure 41: Enabling recording channel for the external DSM camera.

4.3.1.2 Enable Main Stream

Navigate to **Config > Surveillance > Record > Main Stream** and Enable Channel 4.

Resolution = 800P / Frame Rate = 20 / Quality = 2 / Encode = H264

Note: Camera might default to H265, necessary to change to H264.

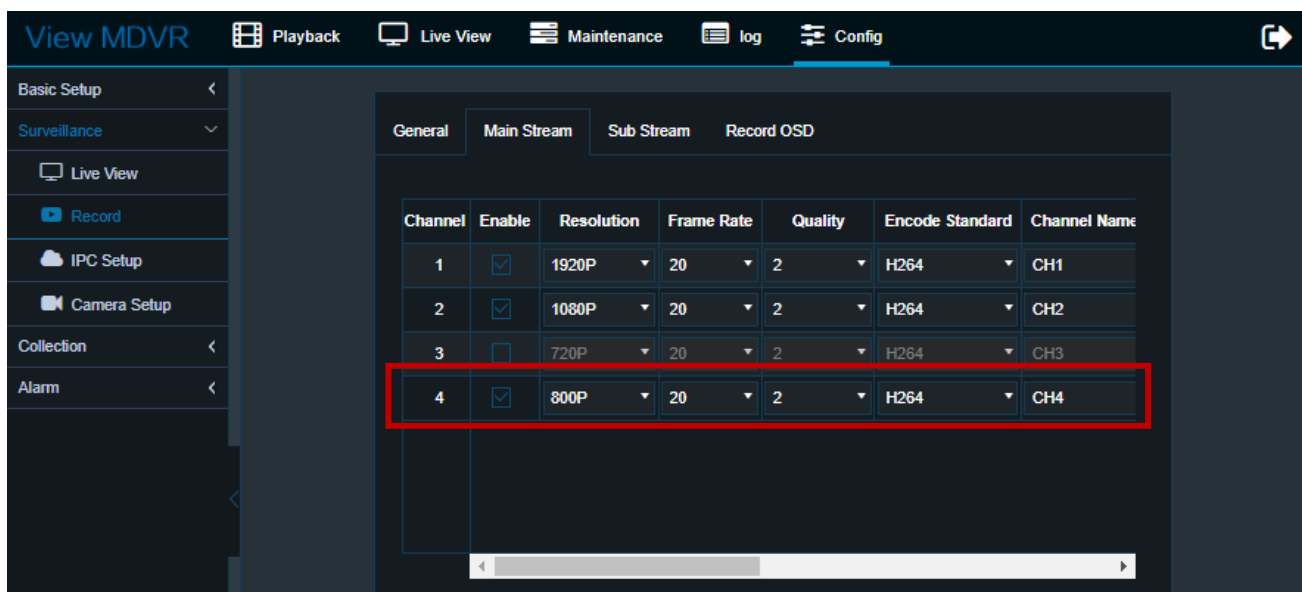

Figure 42: Setting Main stream for the external DSM camera - Part 1.

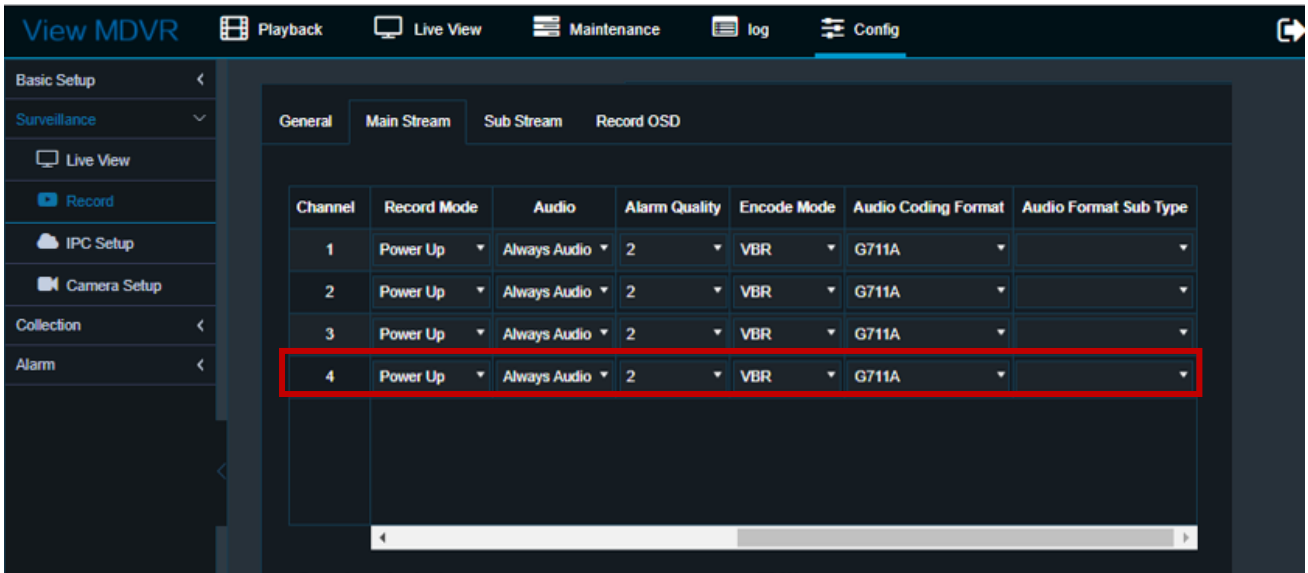

Figure 43: Setting Main stream for the external DSM camera - Part 2.

4.3.1.3 Enable Sub Stream

Navigate to **Config > Surveillance > Record > Sub Stream** and Enable Channel 4.

Resolution = D1 / Frame Rate = 10 / Quality = 3 / Encode = H264

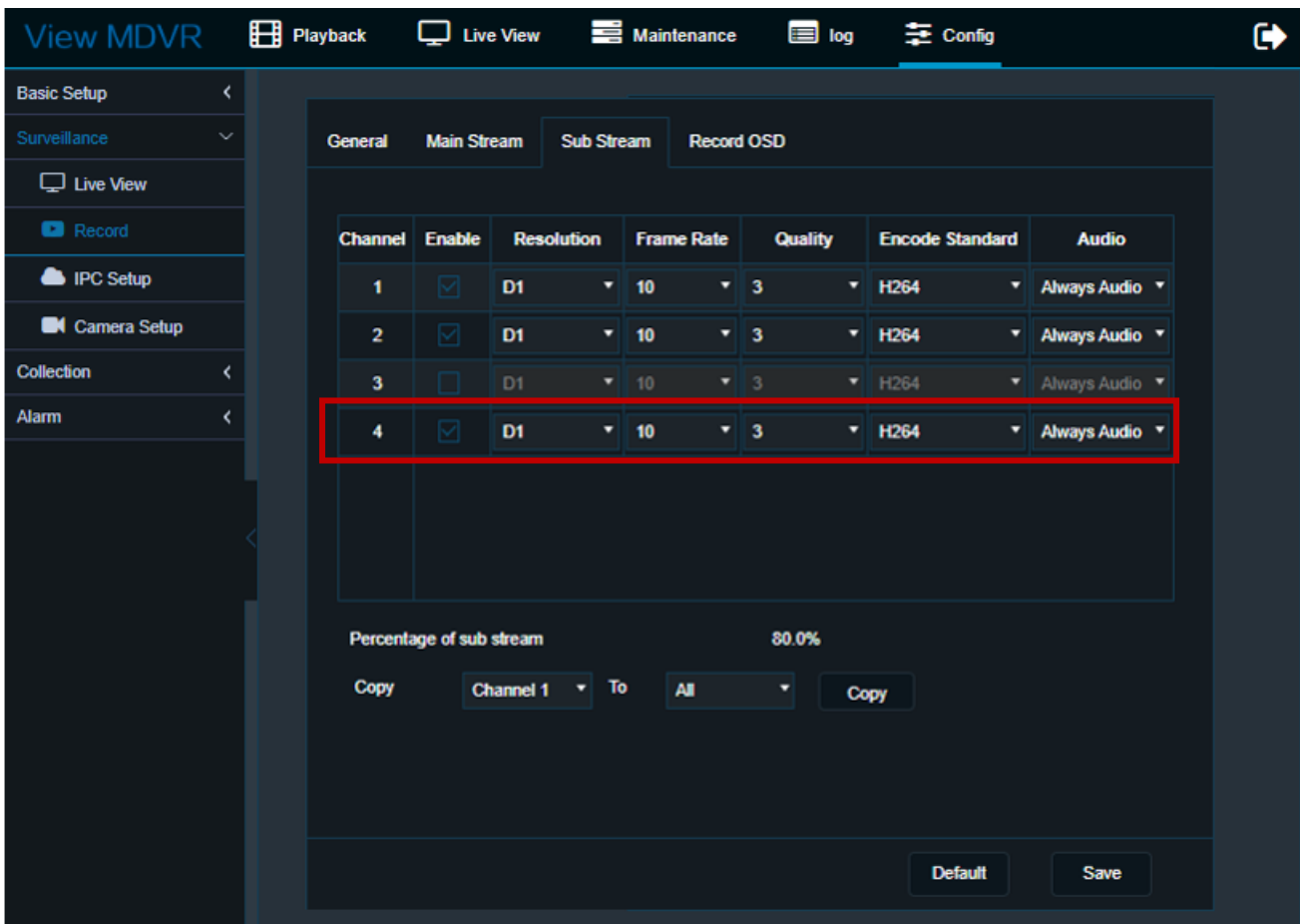

Figure 44: Setting Sub stream for the external DSM camera

4.3.1.4 Enable DSM camera for Driver AI

You need to ensure DSC camera is disabled so the DSM camera will be used for driver AI detections.

Navigate to **Alarm > AI App > Algorithm Calibration** and make sure CH2 and CH3 are set to none. CH4 will be used but is not visible (to be addressed in future SW versions).

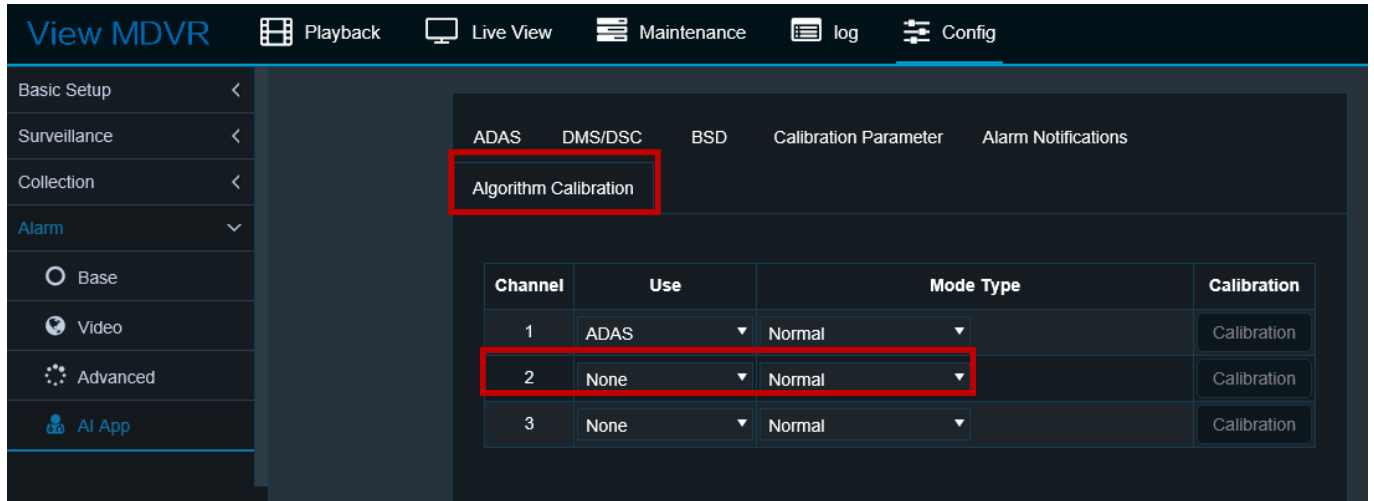

Figure 45: Disabling channel 2 for usage of external DSM Camera

4.3.1.5 Ensure IP camera is setup on correct Channel

When connecting the IPC camera, you need to ensure that the correct channel is setup for IP channel.

Navigate to **Surveillance > IPC Setup** and if CH4 is not enabled, enable CH4. Then press the search icon to detect the channel and enable it.



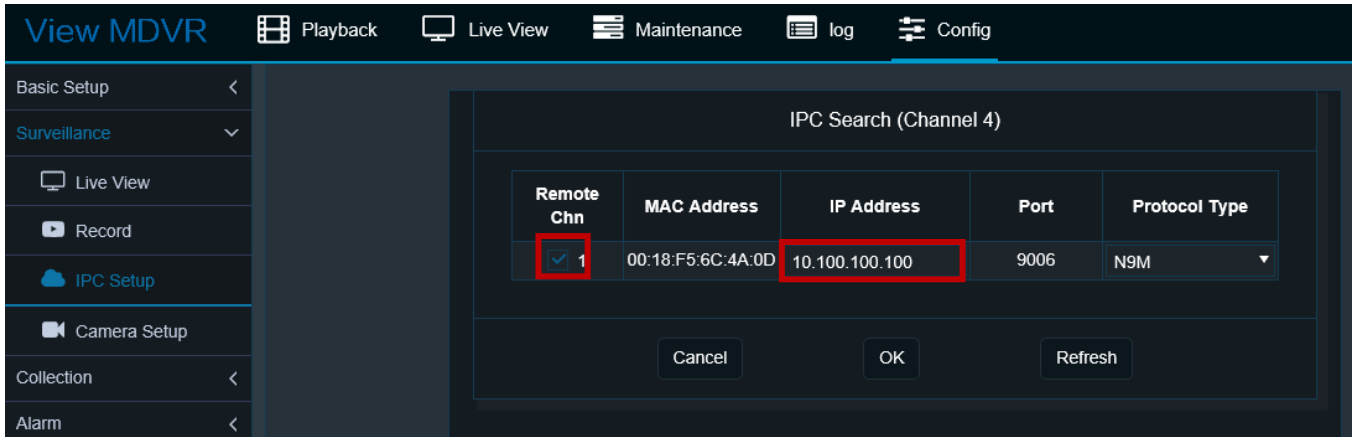

Figure 46: Setting up IPC camera addressing

Note: By default DSM camera does not require a password. However, it is possible that an IPC was configured to request. If the DSM Camera is not working, try using the username/password admin/admin.

4.3.2 Requirements for Installation Position

IMPORTANT

1. If the A-pillar camera (referred to as C29N in general) is selected, the DSM camera shall be installed on the A-pillar on the driver's side, with the curved side facing the driver's face.
2. The DSM camera lens shall be 80-110 cm away from the driver's face. For best results 70-90cm (27.6 – 35.4 inches) are recommended.
3. The installation height of the DSM camera on the A-pillar shall be:
 - I. Below the drivers eyes
 - II. No More than 10cm above the maximum height of an adjustable Steering wheel
 - III. The DMS camera should be mounted in a Slight upward and angled inward.
 - IV. Verify installation angle as per Figure 47 and utilising the installation App



Figure 47: A-Pillar mount installation

- In the event of installation on dash (crescent shaped C29N), the labelling side of the DSM camera must face down (with the arc side up).
- After angle adjustment and calibration, the protective film on the DSM camera must be removed, and the DSM camera must be locked with a socket head wrench to avoid shaking up and down and left and right.



Left hand driver A-Pillar installation with Arc side facing the driver and cable to bottom



Right hand drive A-Pillar installation with arc side facing driver can cable to top



Dash mount installation with arc side facing driver



CANNOT install this way, above driver

4.3.3 Requirements for Installation Angle

Auxiliary adjustment through real-time preview screen after the equipment is powered on:

- Adjust the angle of the DSM camera up and down, and left and right, to ensure that the driver's face appears in the middle of the video screen and the lower edge of the screen is below the driver's chest.
- Make sure that the fill light of the DSM camera faces toward the driver's face (the fill light/IR LED shall not face toward the seat belt; otherwise, it will lead to video overexposure).
- Make sure that there is no other object (such as steering wheel) in the DSM video screen that will block the driver's face and the seat belt features.



Figure 48: Proper view of the driver

4.3.4 Installation Steps

1. First, power on the equipment and connect it with the Veyes APP. Enter the real-time preview screen, and first check whether the driver stands right side up in the screen when the target installation position and the labelling surface of the camera faces toward the A-pillar (with the arc side facing toward the driver).

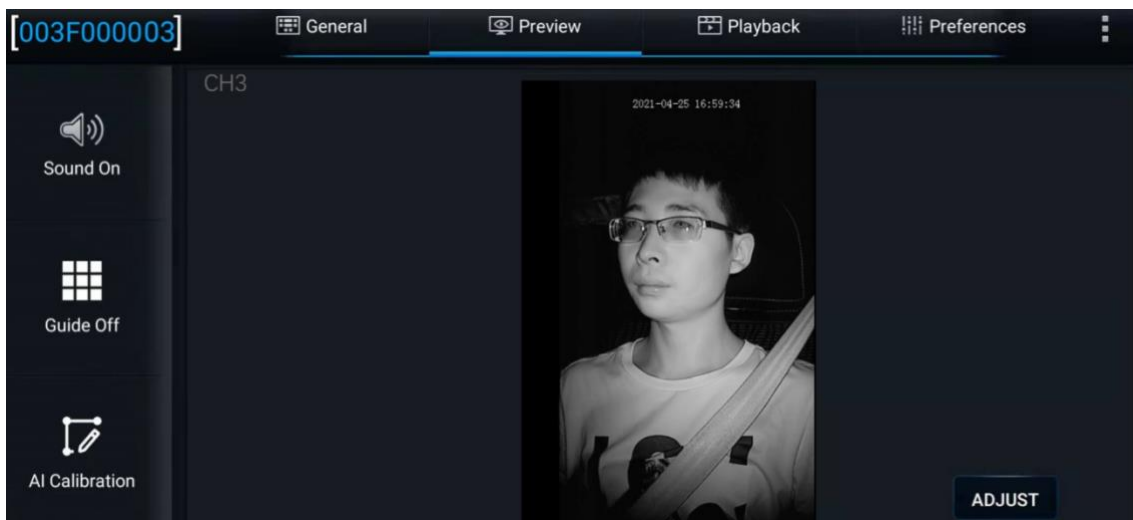

Figure 49: Checking the previews in the Veyes App

2. Verify the correct field of view, C29N Camera will automatically rotate based on the chosen installation position.
3. After meeting the above requirements using DSM camera view, tighten the upper screw of the DSM camera mount (with the lower screw of the mount not tightened temporarily, to adjust the angle of the camera up and down).



Figure 50: Tighten the upper screw of the DSM camera mount

4. Adjust the left and right-angle joints of the DSM camera through the hexagon socket screws, to adjust the angle of the DSM camera left and right.



Figure 51: Adjusting the angle joints

5. After adjusting the angle of the DSM camera up and down/left and right, make sure that the driver sits according to normal driving habits and posture, to meet the following conditions:
 - a. Make sure that the driver's face appears in the middle of the video screen, and the lower edge of the screen is below the driver's chest.

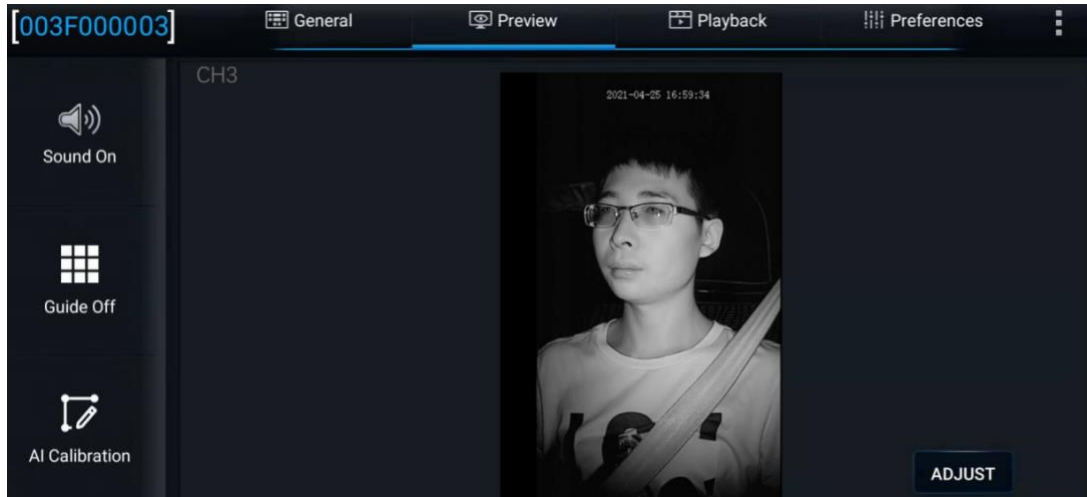

Figure 52: Verifying driver position in the preview screen

- b. Make sure that the fill light (IR LED's) of the DSM camera faces toward the driver's face (the fill light shall not face toward the seat belt; otherwise, it will lead to video overexposure).
 - c. Make sure that there is no other object (such as steering wheel) in the DSM video screen that will block the driver's face and the seat belt.
6. Tighten the lower screw of the DSM camera mount and the screws at the left and right-angle joints to ensure that the camera will not shake up and down or left and right.



Figure 53: Tighten the lower screw of the DSM camera mount



Correct installation, clear view of Driver with no obstructions

Incorrect, obstruction by steering wheel/hands

Incorrect, Seatbelt cannot be seen

Figure 54: Examples of correct and incorrect A-Pillar Mount installation

4.4 AI Driver Coach (R-Watch) installation (Optional)

By default, the device is not setup to make use of the AI Driver Coach (R-Watch). When using this additional item, you need to ensure that the device is setup correctly.



4.4.1 Wiring Driver Coach

The AI Driver Coach connects to the Main Power Harness via Serial Adaptor Cable

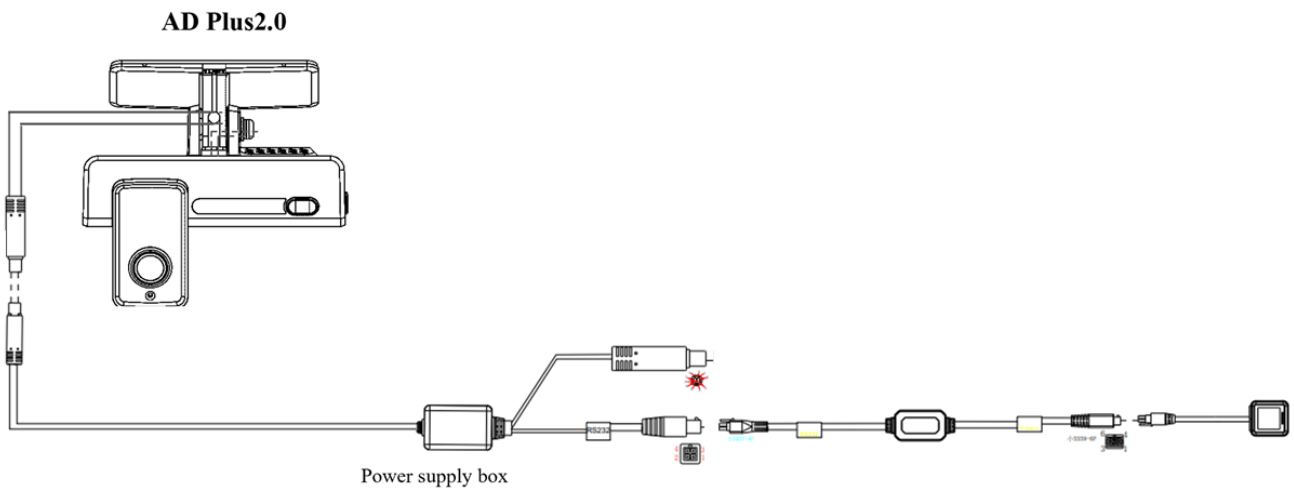

Figure 55: Driver Coach (R-Watch) Wiring

4.4.2 Enabling Driver Coach in device settings

Navigate to Config > Collection > General > Serial Port and make sure R-Watch is selected and baud rate is set to 57600.

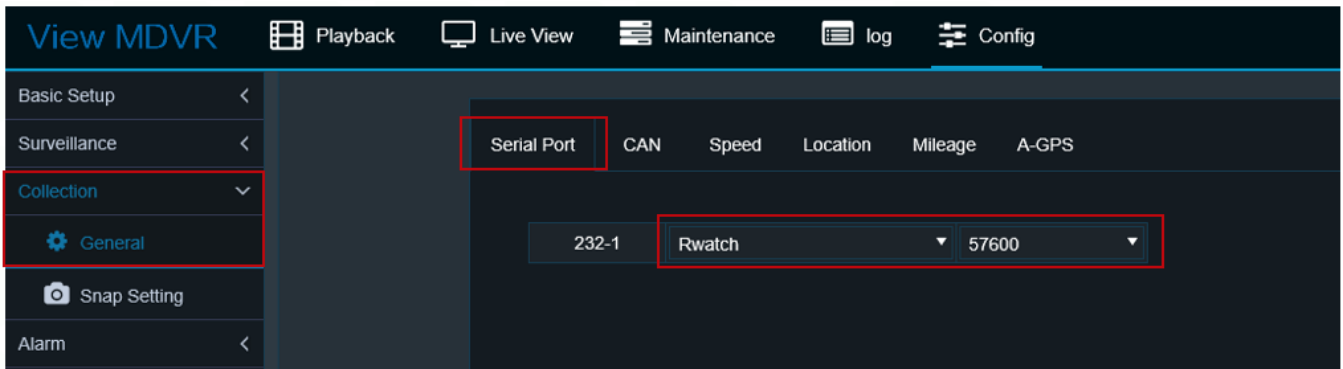

Figure 56: Driver Coach (R-Watch) Wiring

4.5 Additional AHD Camera installation (Optional)

The MiX Vision (AD Plus 2.0) supports the connection of an additional AHD camera. If you connect the external AHD camera, you need to enable channel CH3 and set the Main and Sub Stream settings, otherwise no recording will occur

4.5.1.1 Enable recording on Channel

Navigate to Config > Surveillance > Record > General and enable Channel 3

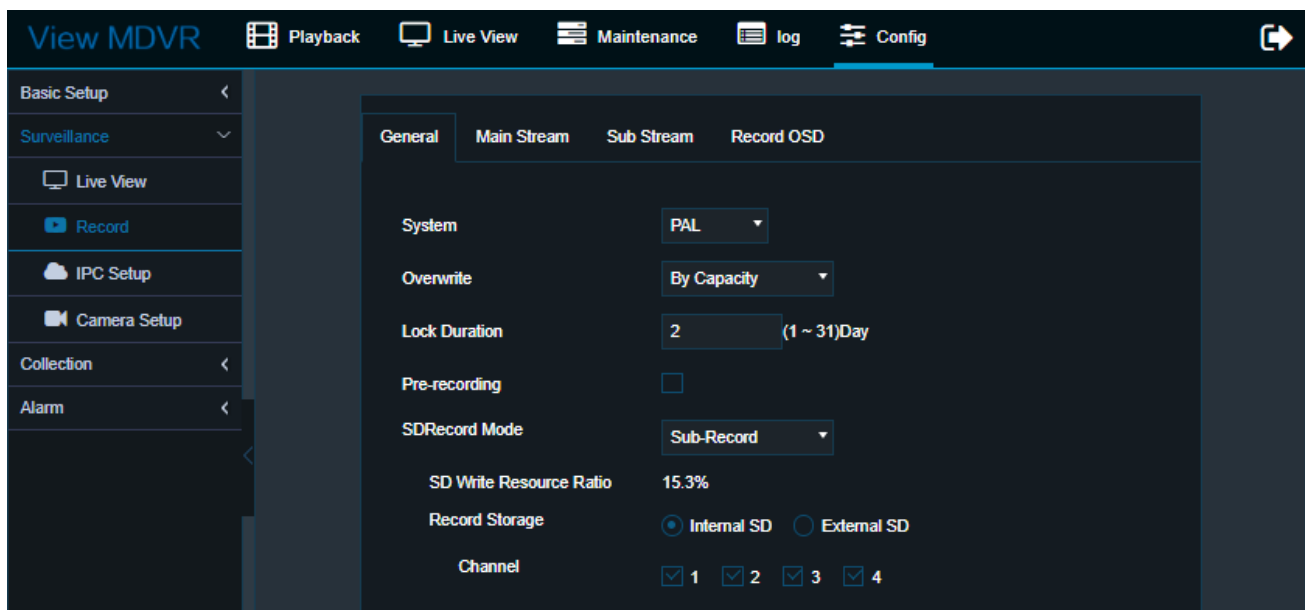

Figure 57: Enabling recording channel for the additional AHD camera.

4.5.1.2 Enable Main Stream

Navigate to **Config > Surveillance > Record > Main Stream** and Enable Channel3.

Resolution = 720P / Frame Rate = 15 / Quality = 3 / Encode = H264

NOTE: Depending on which camera is used, the resolution may be different (according to the camera specs). Try to keep Quality to 3.

If you get a blank screen on preview, the resolution was set too high for the camera, so it would be necessary to lower the settings.

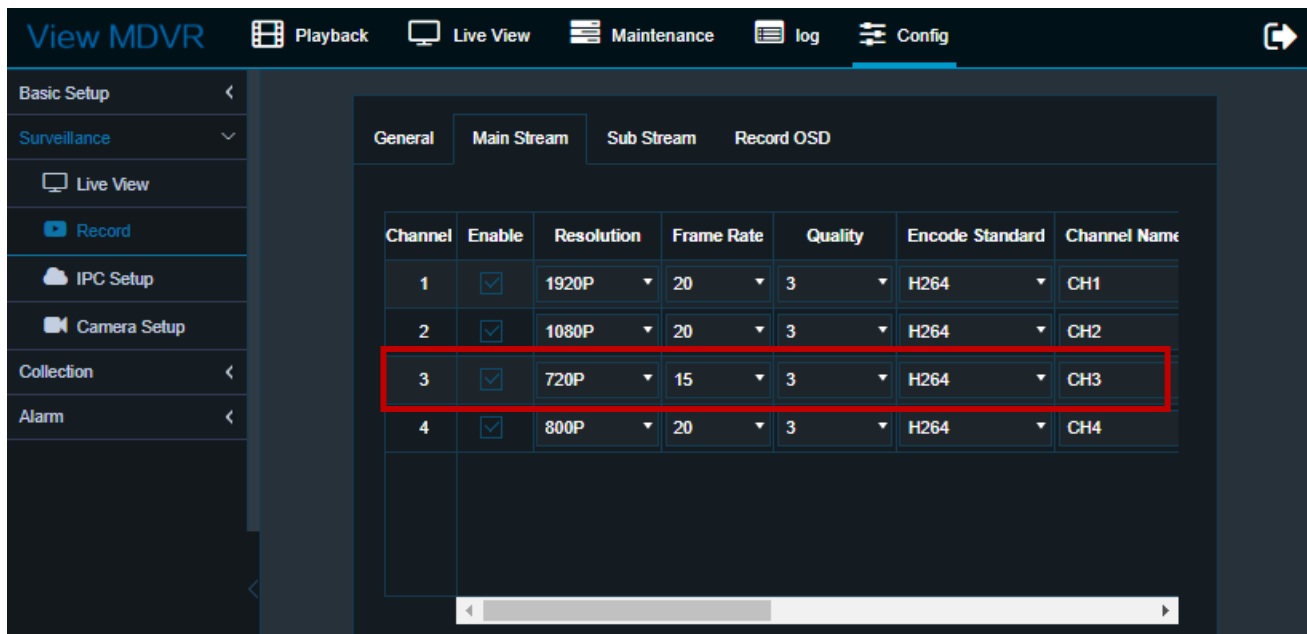

Figure 58: Setting mainstream for the additional AHD camera.

4.5.1.3 Enable Sub Stream

Navigate to **Config > Surveillance > Record > Sub Stream** and Enable Channel3.

Resolution = HD1 / Frame Rate = 10 / Quality = 3 / Encode = H264

NOTE: Depending on which camera is used, the resolution may be different (according to the camera specs). Try to keep Quality to 3.

If you get a blank screen on preview, the resolution was set too high for the camera, so it is necessary to lower the settings.

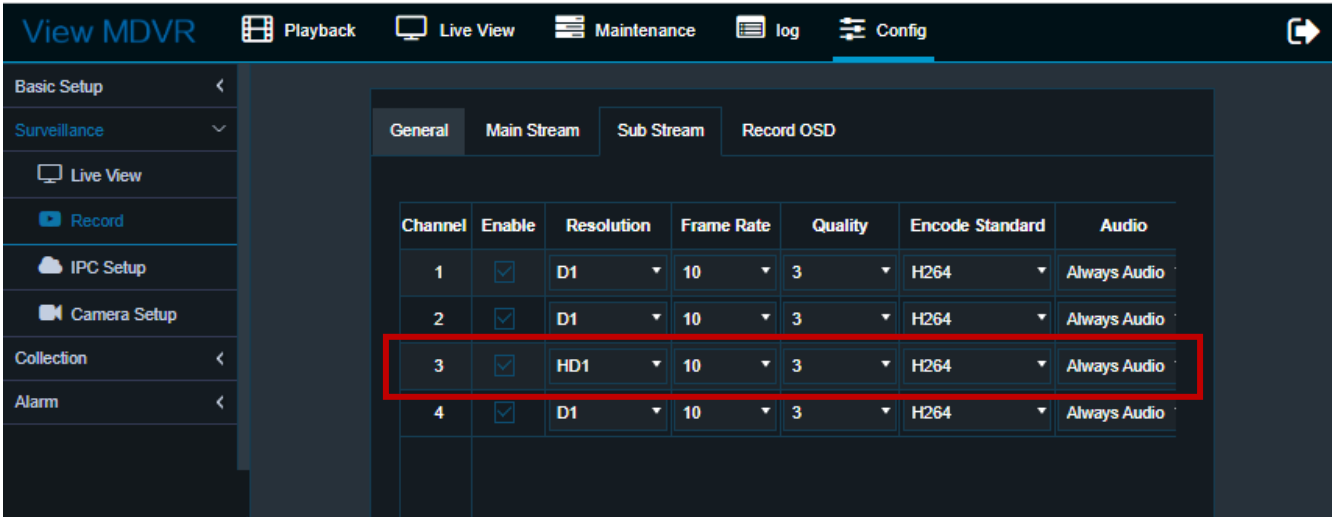

Figure 59: Setting Sub stream for the additional AHD camera.

4.6 Checking Communication and GPS Positioning

4.6.1 Checking connection with mobile network

After installing the device, check if it has successfully connected to the Mobile network.

Go to **Maintenance > Device Module** and check if the Module 1 Status is the same shown below. Network type may vary if 4G network is not available

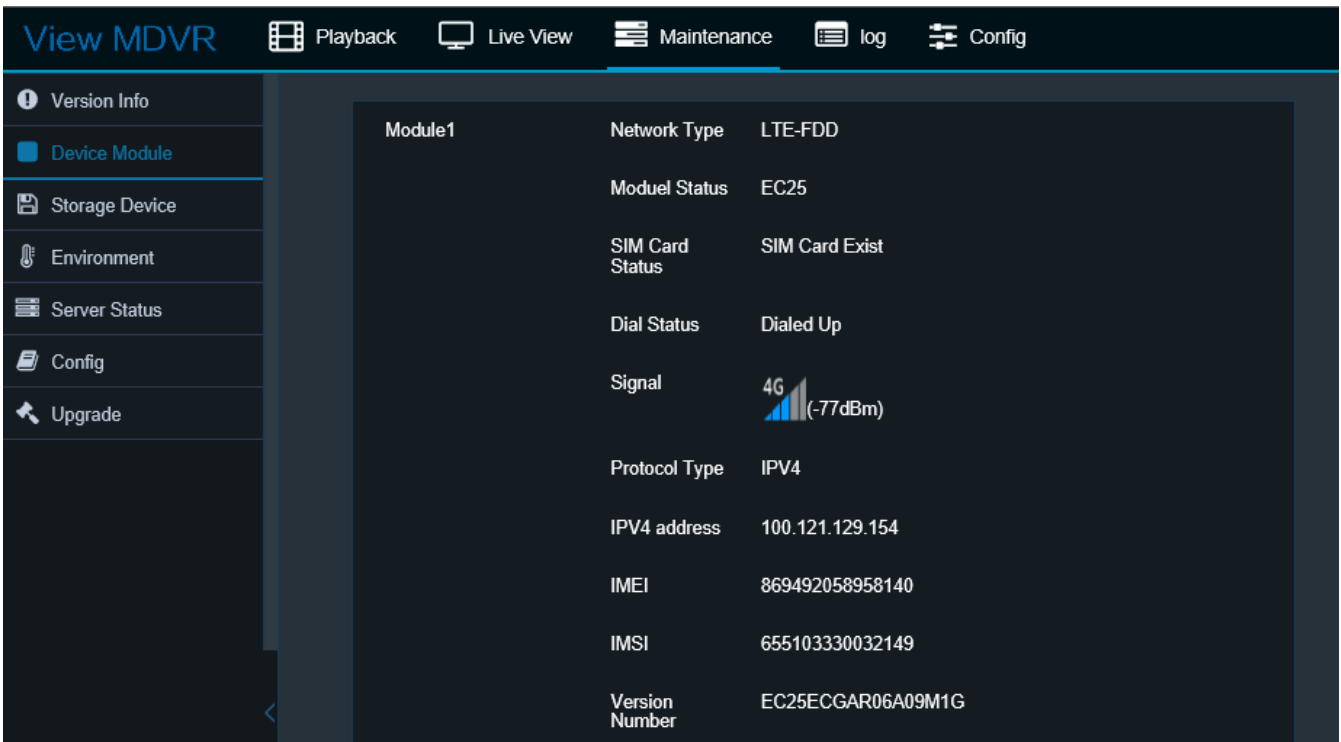

WIFI Module	Connect Status	Start Success
	ESSID	ST-00D20004F7
	IPV4 address	192.168.240.1
	MAC Address	10:38:1F:DF:3B:D6
Satellite Location Module	Moduel Status	Normal
	Location Source	GPS
	Location Plant Number	12
	Location Angle	180.90
	Speed	0 KMH

Figure 60: indicates connection to the Mobile network and GPS positioning.

4.6.2 Checking GPS reception version

After installing, check if the GPS module has successfully detected the satellite network.

Go to **Maintenance > Device Module** and check if the Satellite Location Module are as expected (Status = Normal, Source = GPS and Location Plant Number >=4 (See previous picture).

5 Calibration

5.1 Basic Configuration

5.1.1 Device Time Setup (Required)

The device time must be correctly setup to ensure that the videos are uploaded and shown at the MiX Fleet manager. Please follow the instructions below.

- On the Veyes App, go to **Preferences > Basic Setup > Time Setup**. On the Web Page go to **Config > Basic Setup > Time Setup > General**
- Enable the **Cross Time Zone Enable** checkbox (**Time Zone** is automatically set to GMT)
- Select your **Local TimeZone**.

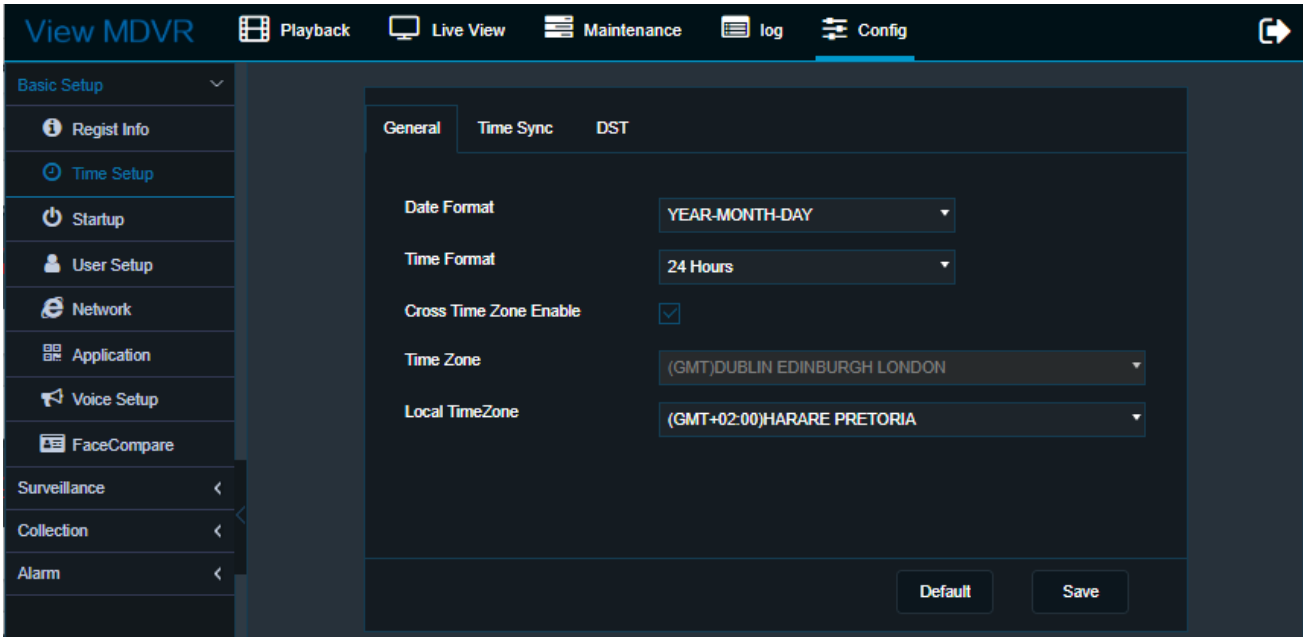

Figure 61: Time Zone setting.

NOTE: if Cross Time Zone is disabled, uploaded videos will not be synchronized with the events in MFM and the videos will not be available.

5.1.2 APN Setup (If required)

Enter the APN details of the SIM Card you intend to use. Default is “internet”

On the Web app, go to **Config > Basic Setup > Network > Communication Module**

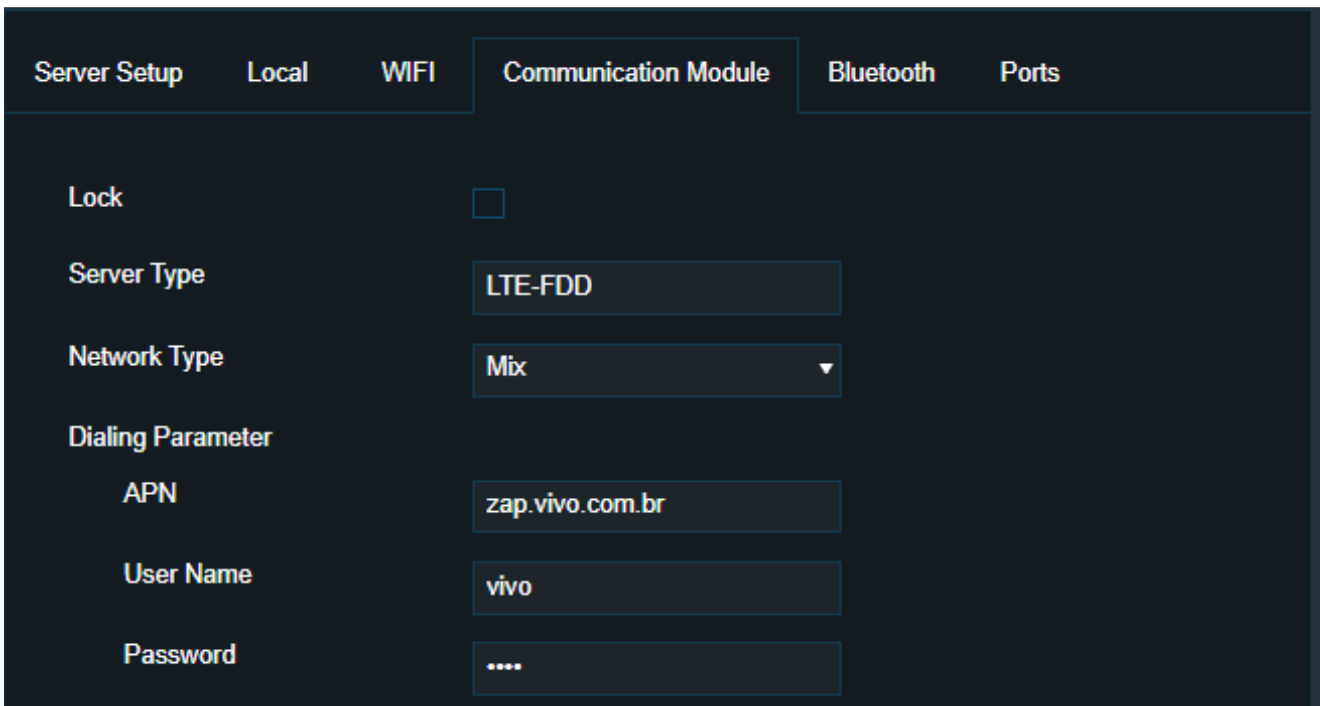

Number	<input type="text" value="*99#"/>
Certification	<input type="text" value="PAP"/>
Carrier	<input type="text" value="Auto"/>
Protocol Type	<input type="text" value="IPV4"/>
Active Mode	<input type="text" value="Always"/>
Number1	<input type="text"/>
Number2	<input type="text"/>
Number3	<input type="text"/>

Figure 62: APN Setup.

On the Veyes App, go to **Preferences > Basic Setup > Network > Communication Module** and enter the APN and user details.

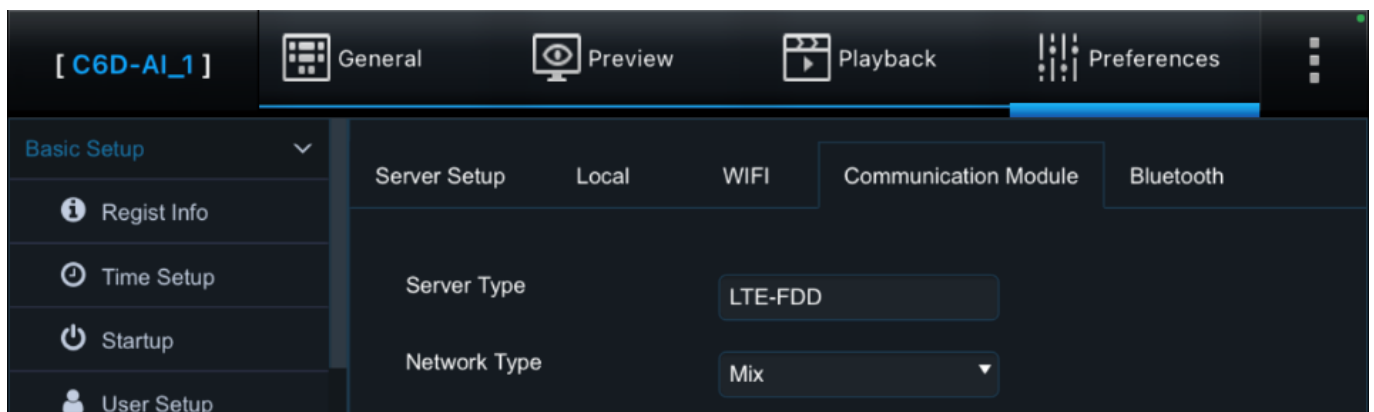

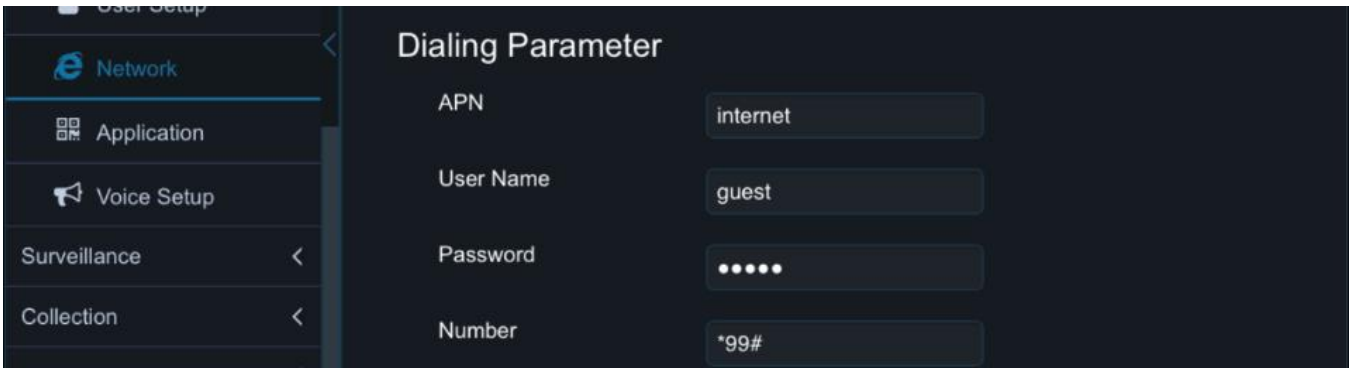

Figure 63: APN Setup using Veyes App

5.1.3 Change server address (If required)

The device will be preprogrammed with the server address from the factory. In some cases, it would be needed to change it if you want to move the device to a different datacentre.

On the Veyes App, go to **Preferences > Basic Setup > Network > Server Setup** and enter the Server DSN and Port details.

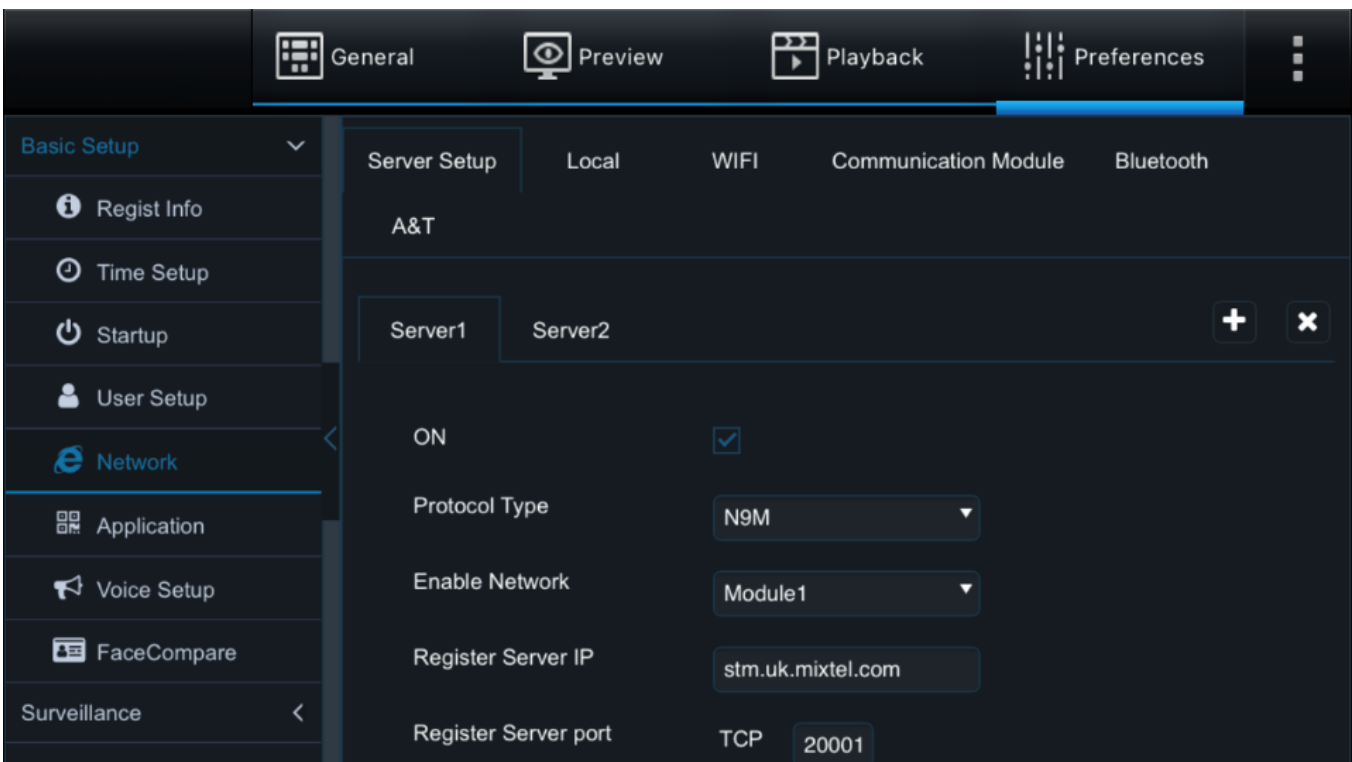

Figure 64: Server Address Setup using Veyes App

On the Web app, go to **Config > Basic Setup > Network > Server Setup**

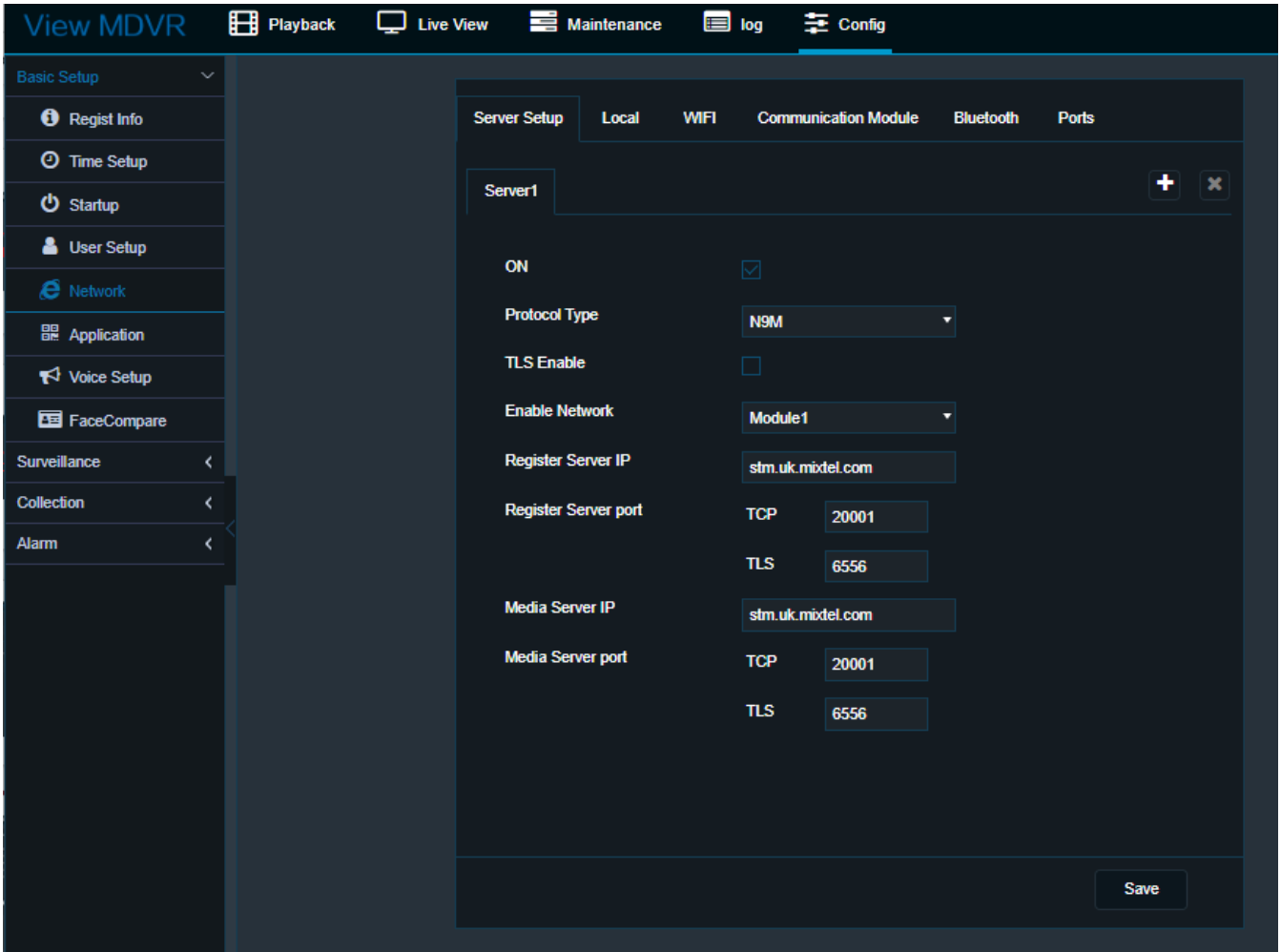

Figure 65: Server Address Setup using Web App

Server Overview:

Environment	Device DNS	Device Port
ZA	stm.za.mixel.com	20001
ENT	stm.ent.mixel.com	20001
UK	stm.uk.mixel.com	20001
AU	stm.au.mixel.com	20001
US	stm.us.mixel.com	20001

Note: It is possible to register more than one server, but data consumption will be multiplied by the number of active servers!!!

5.1.4 5.1.4 Speed input selection (if required)

By default, the GPS is used as source of speed for the event detection. However, it is also possible to obtain the speed information through CAN, OBD2 or a pulsed signal.

With the App open, go to Preferences > Collection > General > Speed and select the correct speed input source and press Save.

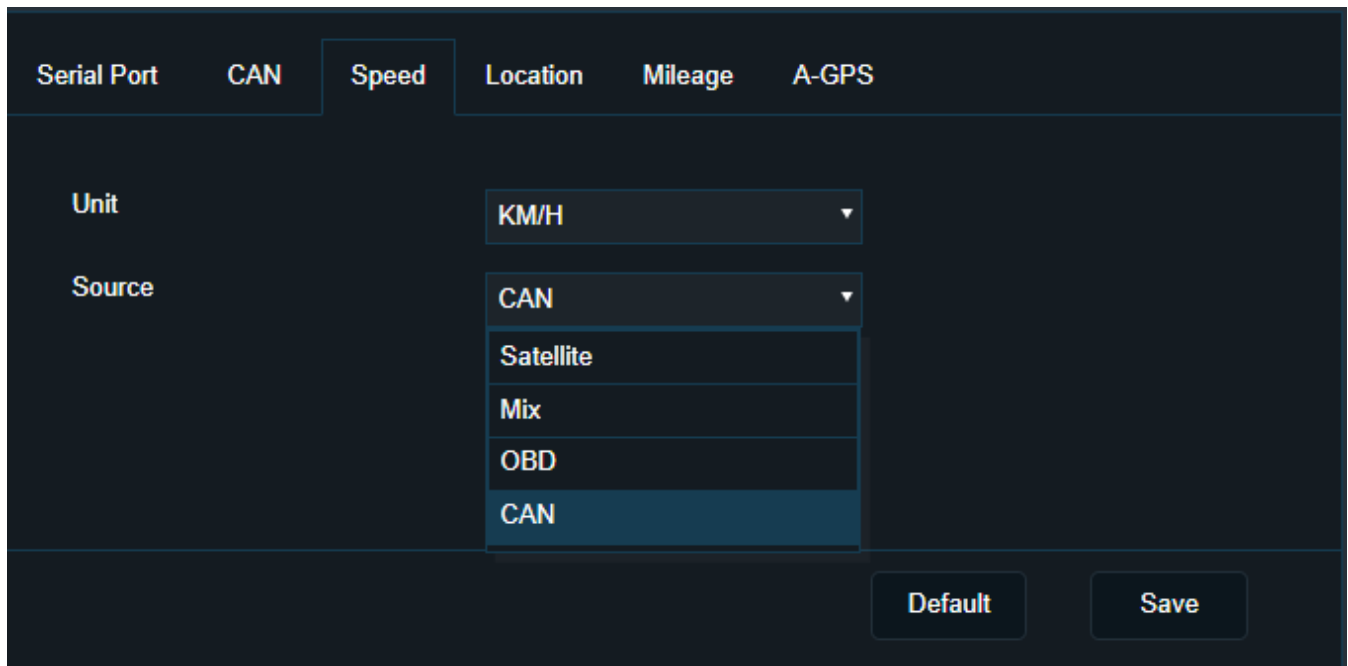

Figure 66: Speed Source Selection

Speed unit options:

- **KM/H:** Use KM/H on video overlay and algorithm speeds settings
- **MPH:** Use MPH on video overlay and algorithm speeds settings

Speed Source options:

- **Satellite:** Obtain speed value from GPS data
- **Mix:** When you select Mix for speed source, you can set its priority. There are 6 priorities in total
 - GPS > PULSE > OBD
 - GPS > OBD > PULSE
 - PULSE > GPS > OBD
 - PULSE > OBD > PULSE

- OBD > GPS > PULSE
- OBD > PULSE > GPS
- **OBD:** Obtain speed value from OBD source.
- **CAN:** Obtain Speed form CAN Bus

By selecting the **MiX** option, it allows the configuration of a pulse signal as the source of speed. A calibration is necessary to define how many pulses corresponds to one km.

Figure 67: Selecting Speed source priorities and Pulse signal calibration.

5.1.5 Recording settings (Required)

A correct configuration for the video recording must be carefully performed , to ensure the expected results.

On the Web app go to **Config > Surveillance > Record > General**

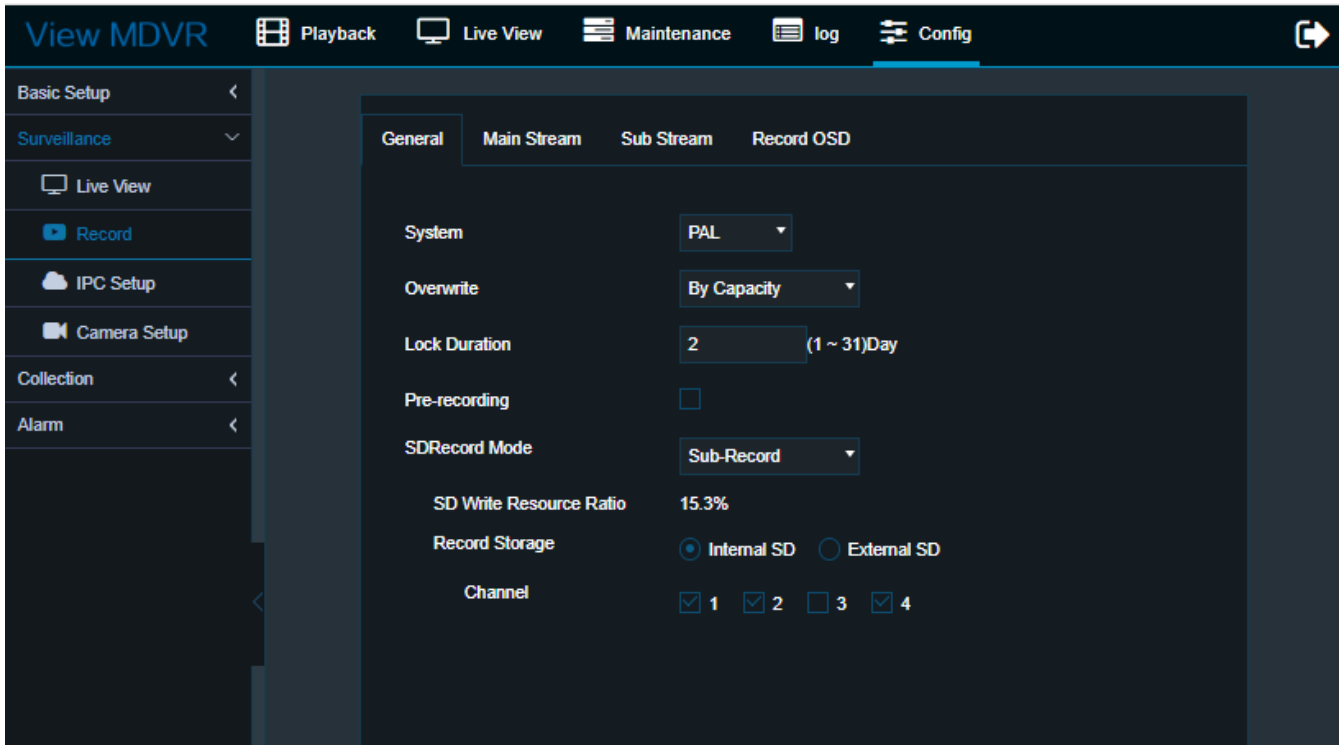

Figure 68: Recording settings.

Section	Recommended Setting	Description
System	PAL	All units to be set to PAL and not NTSC
Overwrite	By Capacity	By Capacity to be used, the System will always keep about 1GB data free on the TF card for file handling.
Lock Duration	1	Do not use this function. If you enable LOCK function, you will reduce the video storage capacity.
Pre-recording	Disabled	
SDRecord Mode	Sub-Record	Sub-Record to be used. All other settings will not store SD video on TF2 and then you will not get event videos on MFM.
SD Write Resource Ratio	%	Auto calculated based on TF card size and resolution settings
Channel	Enabled	All channels that are used need to be enabled, otherwise no videos will not be saved to the TF Cards.

5.1.6 Resolution settings

The VisionAI (AD Plus 2.0) operates with 2 x Micro TF cards. TF1 is used for Main Stream (HD video) and TF2 is used for Sub Stream (SD video). The SD video will be used for all events that occurs.

The device uses the raw video feed for algorithm, but it is recommended to set the AI channels Main stream to highest resolution and 20 frames a second for investigation. Size of video give for event 8 seconds (SD), 15 seconds (HD) and 2.5min Custom Clip request. The video sizes (see next subsections) are estimated and may change due to lighting conditions and environment (driving vs standing, more differences in pixels per second).

5.1.6.1 Main Stream Settings

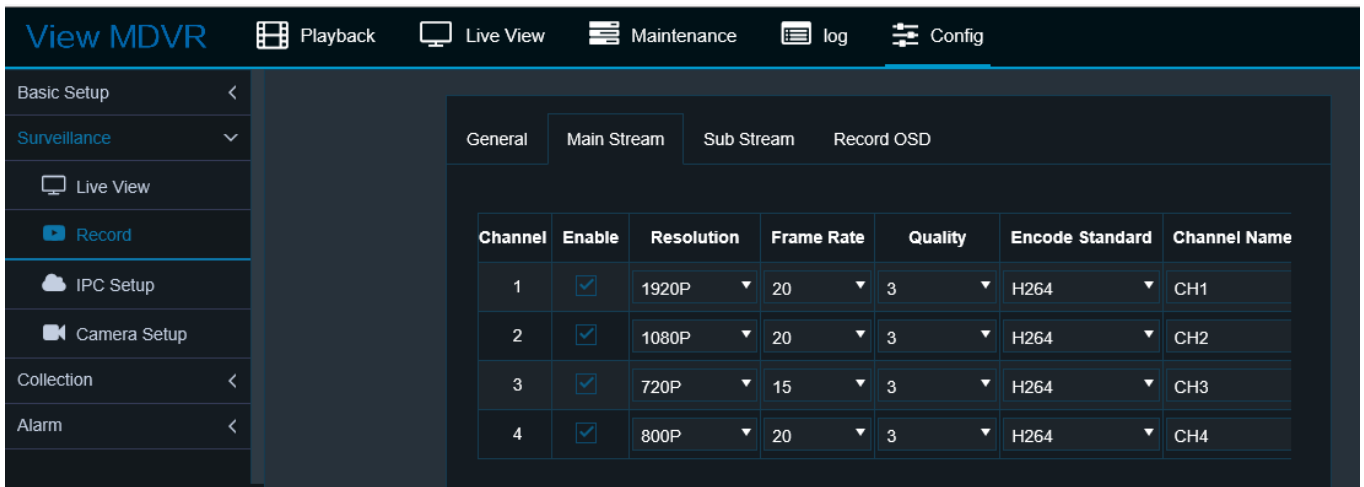

The screenshot shows the 'View MDVR' configuration interface. The 'Main Stream' tab is selected, displaying a table of settings for four channels. The table columns are Channel, Enable, Resolution, Frame Rate, Quality, Encode Standard, and Channel Name.

Channel	Enable	Resolution	Frame Rate	Quality	Encode Standard	Channel Name
1	<input checked="" type="checkbox"/>	1920P	20	3	H264	CH1
2	<input checked="" type="checkbox"/>	1080P	20	3	H264	CH2
3	<input checked="" type="checkbox"/>	720P	15	3	H264	CH3
4	<input checked="" type="checkbox"/>	800P	20	3	H264	CH4

Figure 69: Main stream Settings.

5.1.6.2 Recommended Main Steam Settings

Channel	Resolution	Frame Rate	Quality	Encode Standard	Size: 15s	Size 2.5min
1	1920P	20	3	H264	8.87 MB	100 MB
2	1080P	20	3	H264	8.87 MB	89 MB
3	720P	15	3	H264	5.46 MB	55 MB
4	800P	20	3	H264	4.22 MB	42 MB

5.1.6.3 Sub Stream Settings

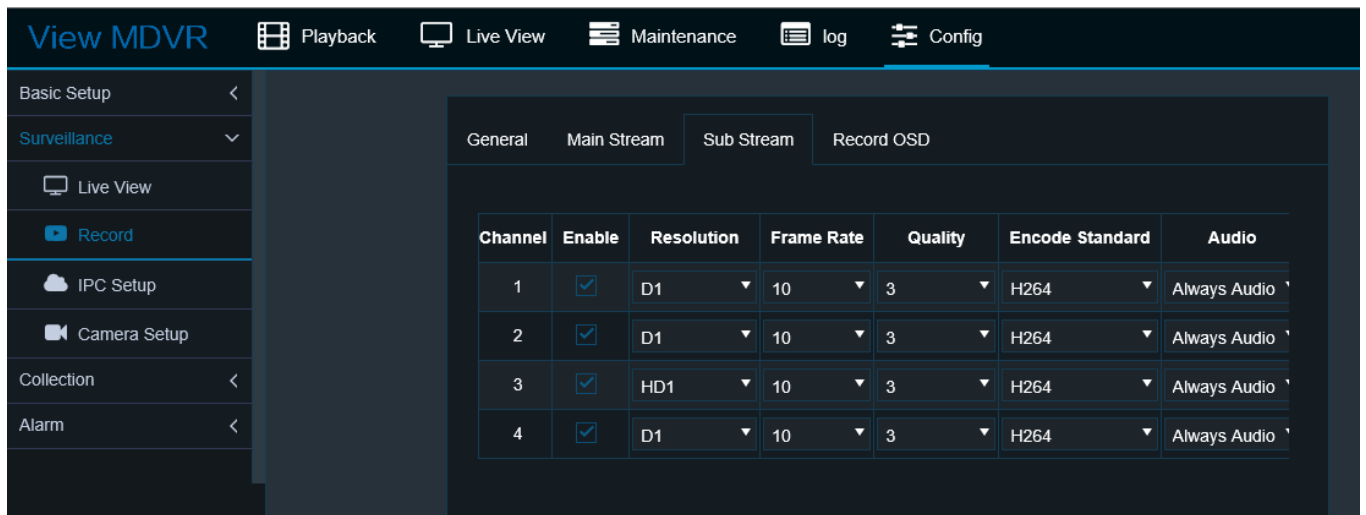

Figure 70: Sub stream settings.

5.1.6.4 Recommended Settings

There are 3 options for resolution, it is recommended to go with D1 settings, but others can be chosen to reduce use of disk space. Table below gives an indication of what the video size would be per resolution.

Channel	Resolution	Frame Rate	Quality	Encode Standard	Size: 15s	Size 2.5min
CIF	10	3	H264	0.33 MB	6 MB	CIF
HD1	10	3	H264	0.52 MB	10 MB	HD1
D1	10	3	H264	0.65 MB	12 MB	D1

NOTE: configuring all channels to D1 is not possible, as it use as it requires more 100% of the sub stream resources.

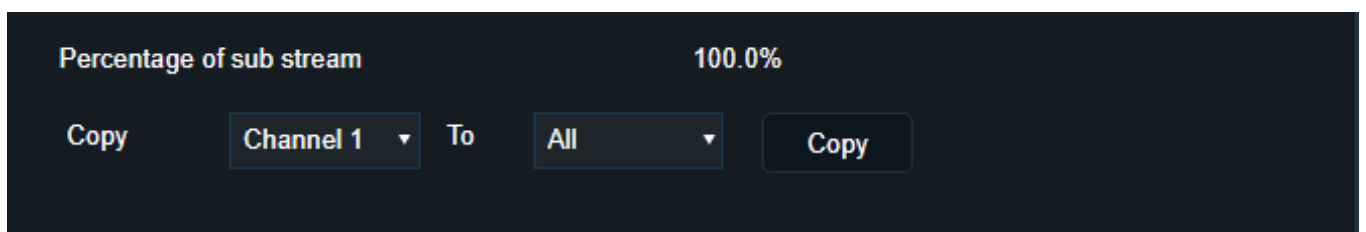

Figure 71: Sub stream resource usage.

Best quality can be achieved with 3 channels in D1 and one in HD1.

5.2 Road Camera Calibration

1. With the App open, go to Preview and select AI Calibration.
2. **IMPORTANT** - Please comply with 4.1 – and insure installation of the AI Camera complies



Figure 72: Select AI Calibration.

3. Select the ADAS Calibration option.

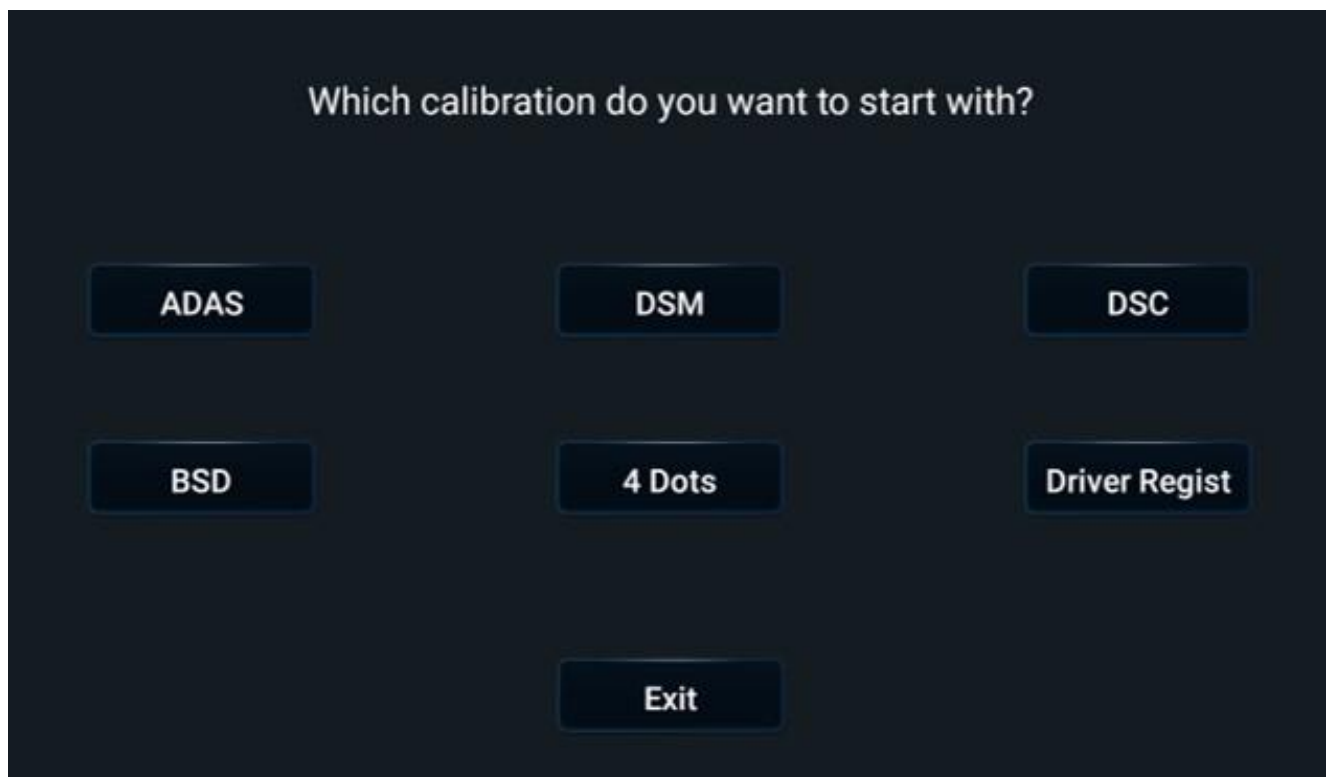

Figure 73: Select ADAS Calibration.

4. Ensure correct camera is selected (1) and press **Calibration**.



Figure 74: Select the front camera.

5. Answer the questions on and press Next.

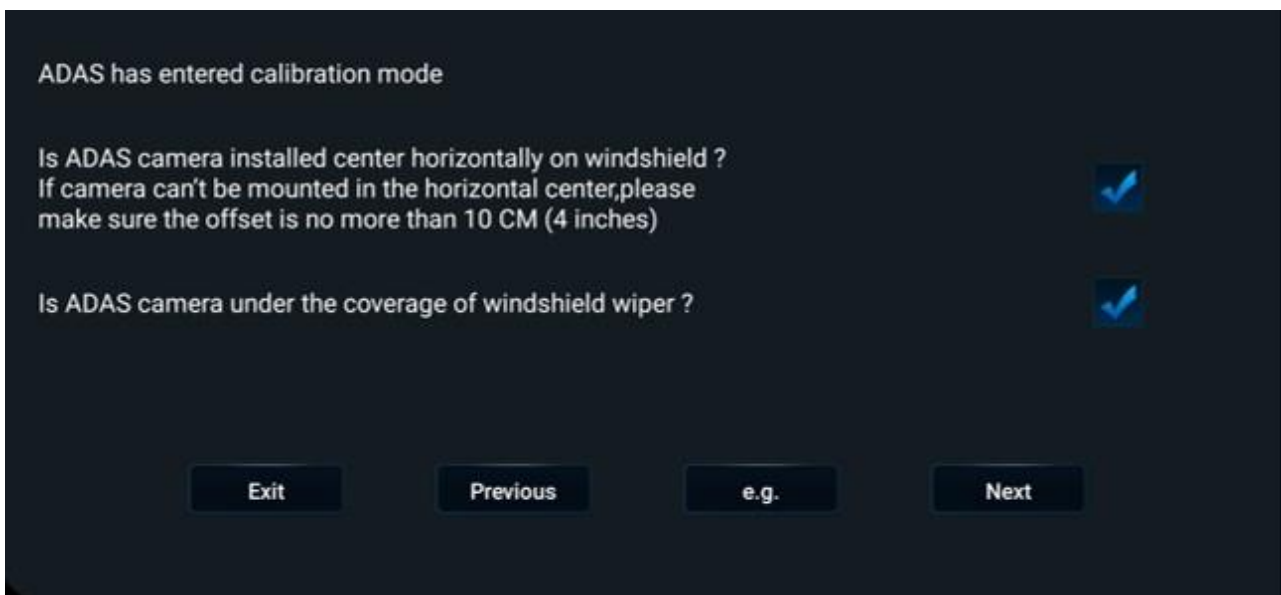

Figure 75: Answers the questions about the camera installation.

6. Enter the camera installation dimensions relative to the vehicle and press next
7. **IMPORTANT** - Please comply with 4.1 – Installation must be between 130-240cm

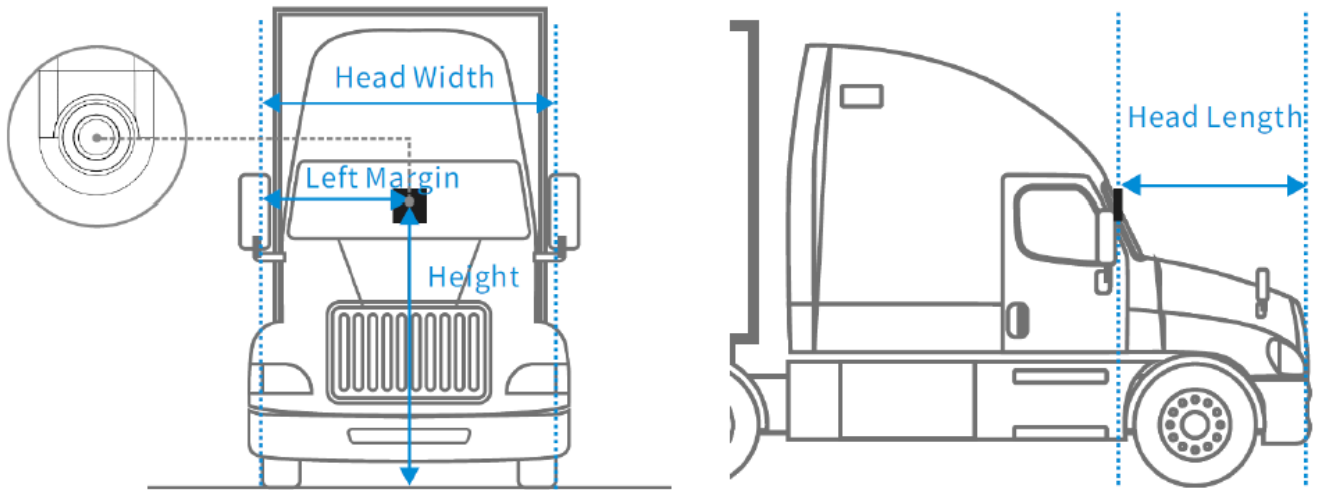

Figure 76: Vehicle measurements used during calibration.

Please input the installation position of ADAS camera :

Unit cm inch

ADAS Camera Install Height	134	(50-400)
ADAS Camera Left Margin	65	(0-400)
Front-end Width	178	(0-400)
Front-end Length	165	(0-400)

e.g. Next

Figure 77: Entering vehicles measurements

IMPORTANT - Please comply with 4.1 – If you put a height or offset measurement that is not with in the tolerance of 4.1 then please do not activate LDW and further raise a support Ticket. Record measurement in the app and on the Job card.

8. Press Next or review ADAS calibration instructions.

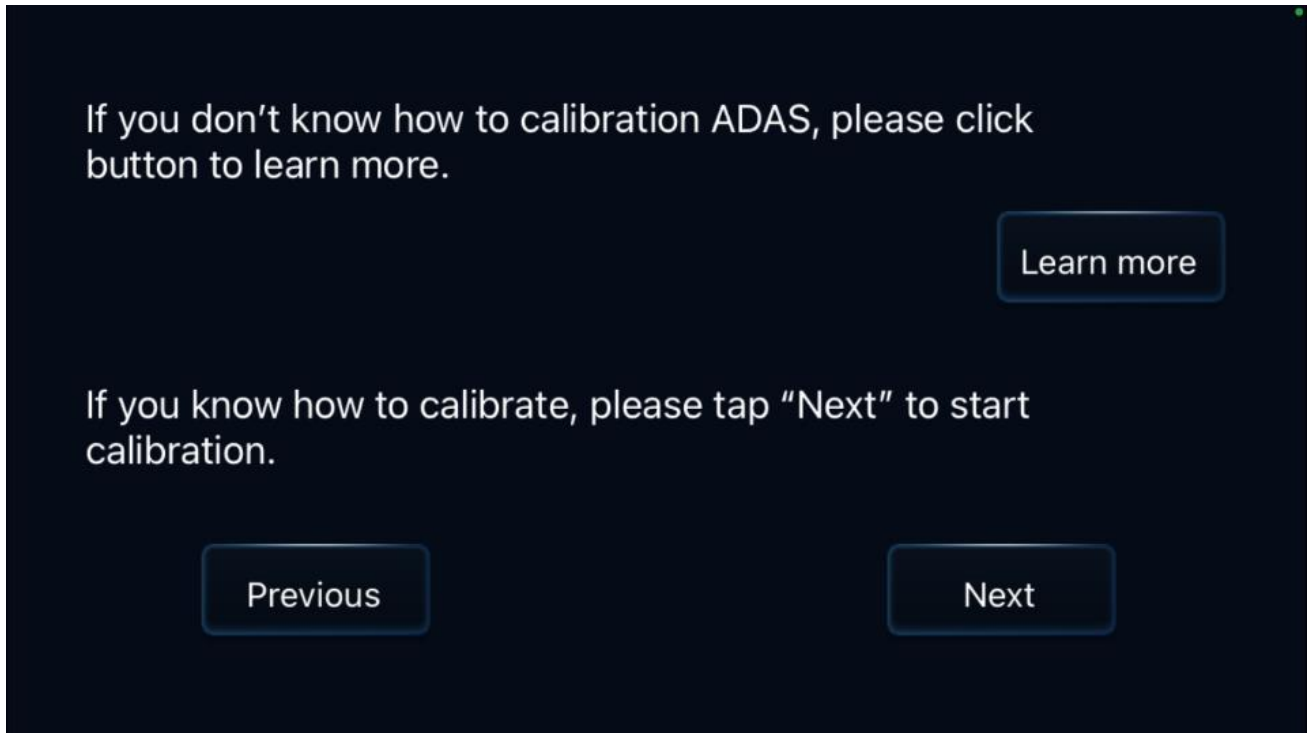

Figure 78: Entering calibration.

9. Press Next to proceed to next screen.

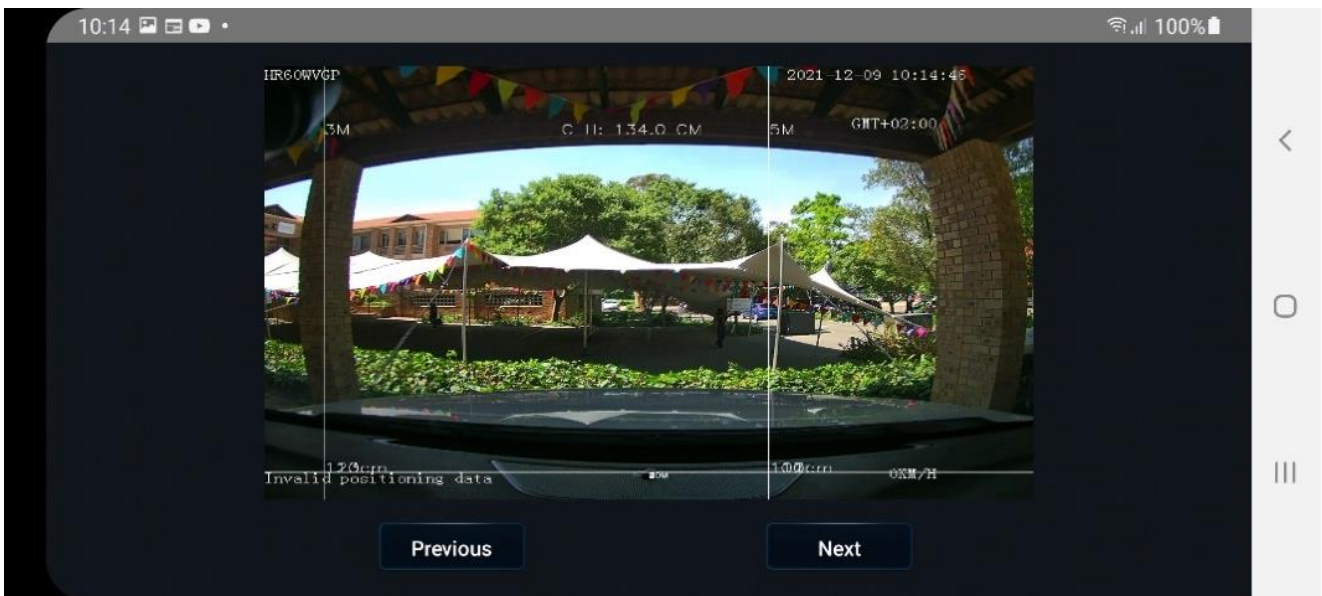

Figure 79: View of calibration screen.

10. Select Yes, to exit ADAS calibration and select GPS source (Satellite, OBD, Pulse) and setup Indicators if used. Select which IO lines are used and select "Pulse Source" or "Source Voltage".

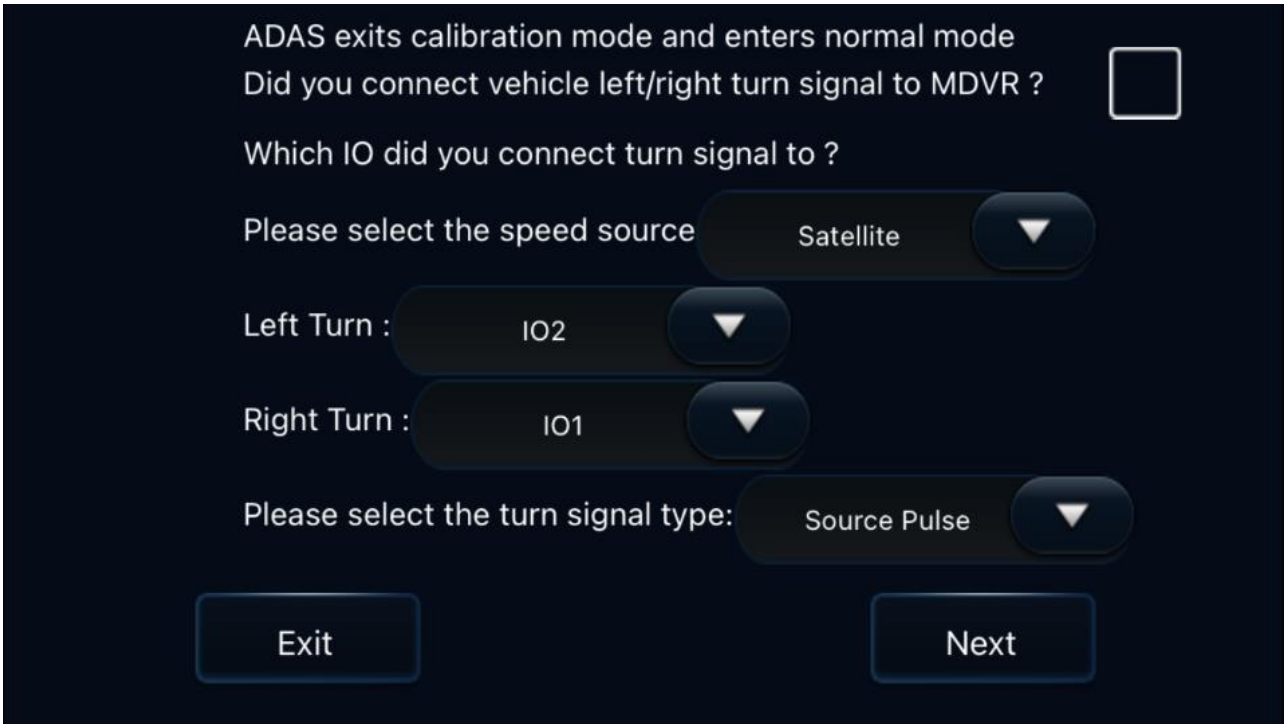

Figure 80: Configure Left/Right turn indicators.

- Pulse Source = Signal received by device is a pulse signal (pulsating)
- Source Voltage = Signal received by the device is a level signal (on/off)

11. Test Left Signal to ensure ON is detected

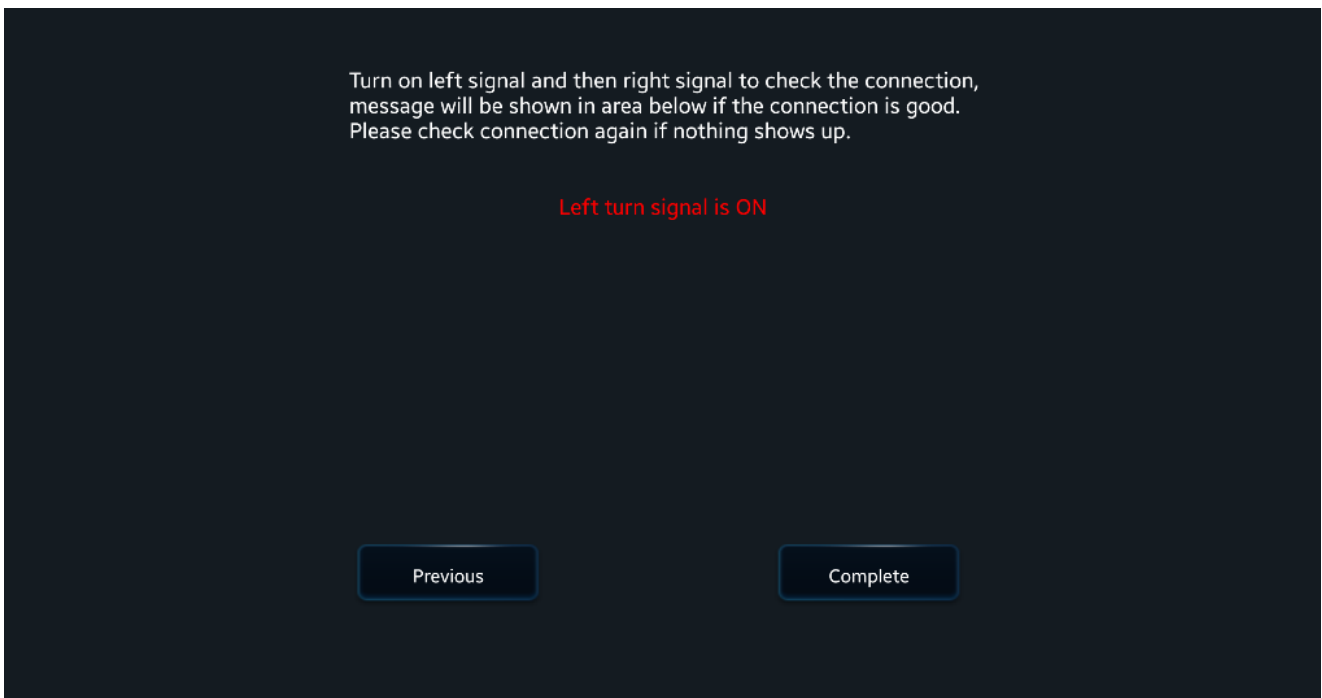

Figure 81: Testing left turn signal.

12. Test Right Signal to ensure ON is detected

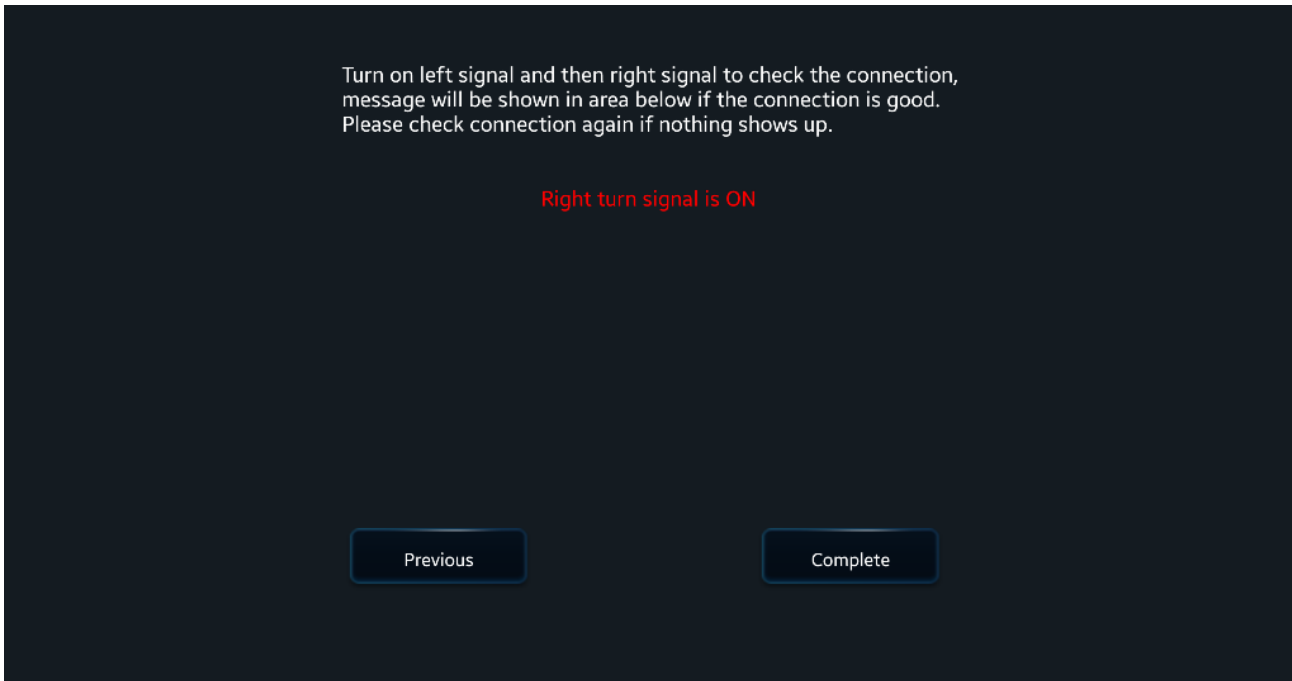
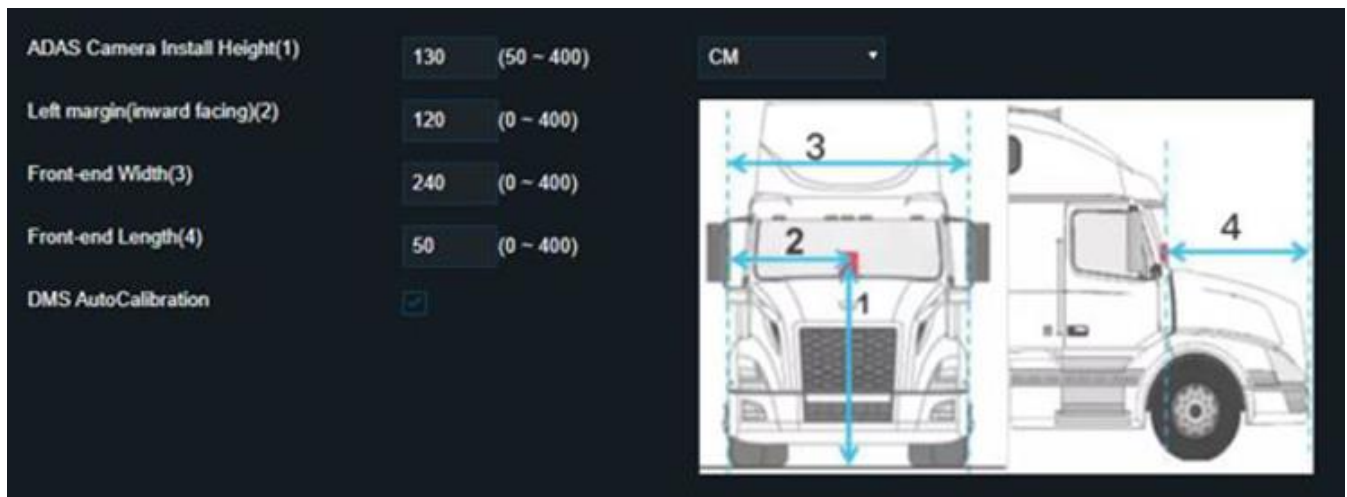

Figure 82: Testing right turn signal.

IMPORTANT: It is possible to modify some of the calibration parameters using the Veyes App or the Web application, outside the calibration process.



IMPORTANT - Please comply with 4.1

Figure 83: Screen for modifying the parameters outside the calibration.

This should be **AVOIDED** as it triggers the start of a calibration process (which can happen in conditions where calibration is not optimal).

5.3 Driver Camera Calibration (DSC) [AD Plus2.0 Only]

This section describes the calibration if the built-in DSC camera is used for Driver Monitoring. If the external DSM camera is used, please skip this section.

1. With the App open, go to Preview and select AI Calibration

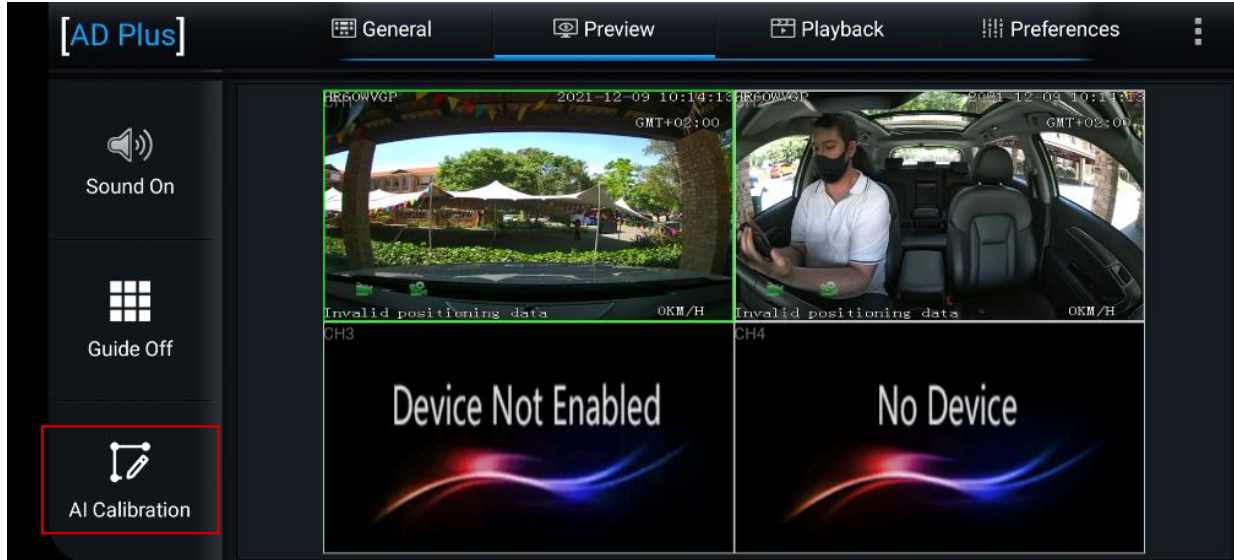

Figure 84: Select AI Calibration.

2. Select the DSC Calibration option

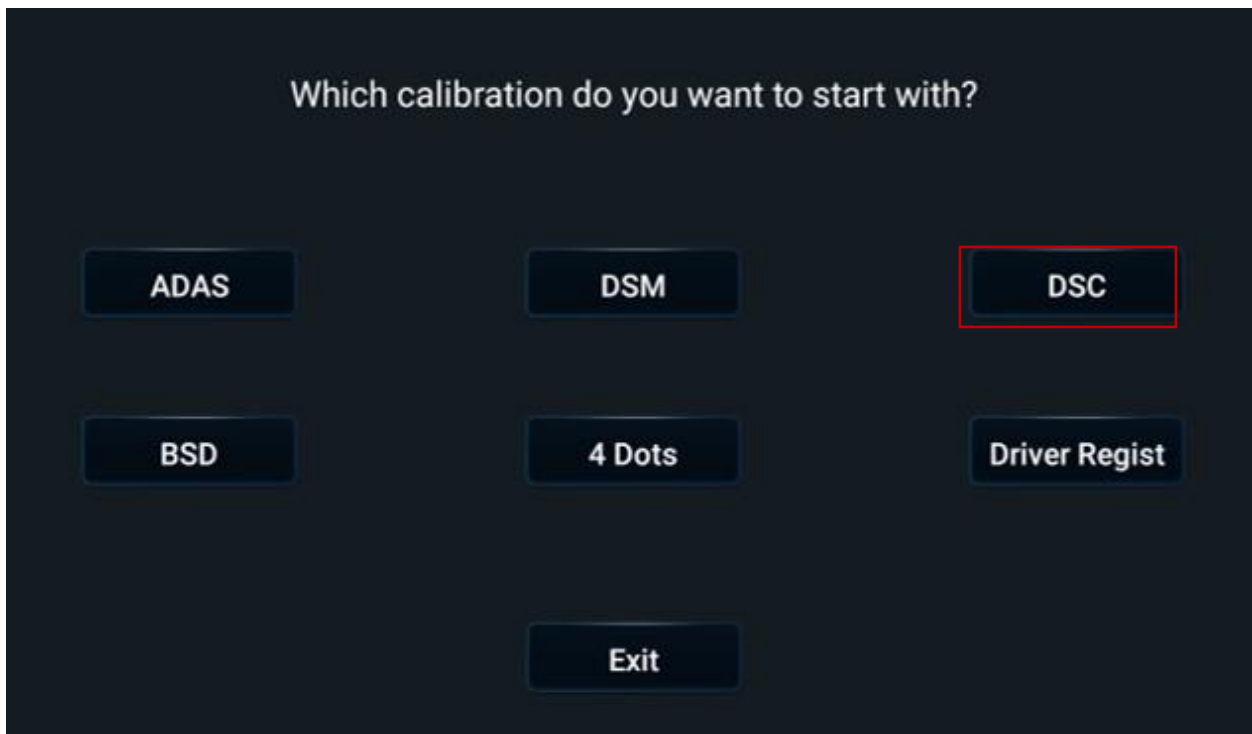

Figure 85: Select DSM (Driver Camera) Calibration.

3. Ensure correct camera is selected (3)



Figure 86: Select correct camera.

4. Select Left-hand or Right-hand drive and press Save then Exit.

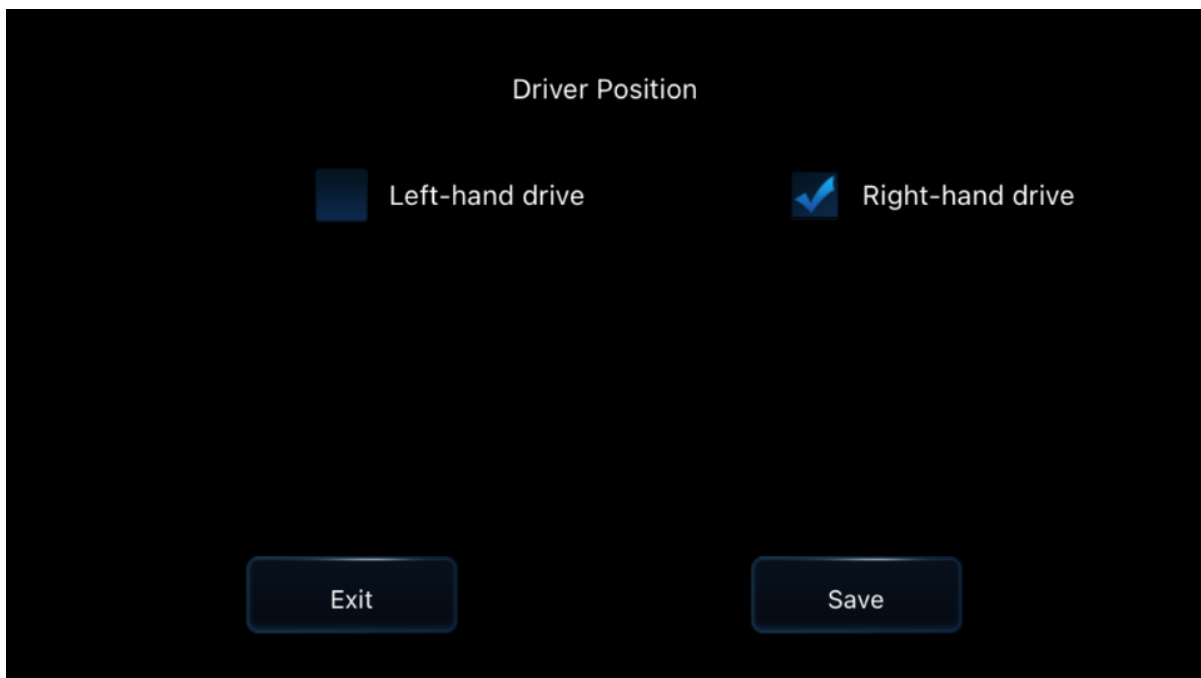

Figure 87: Select driver position.

5.4 Driver Camera Calibration (DSM – external Camera) – Optional Installation

If the external DSM camera (C29N) is used, it is required to disable the internal DSC camera. Set the Channel 2 to None and the VisionAI will use the external DSM camera on Ch4 (not visible in the App).

1. With the App open, go to **Preferences > Alarm > AI App > Algorithm Calibration**
 - Change CH2 from DSC to None

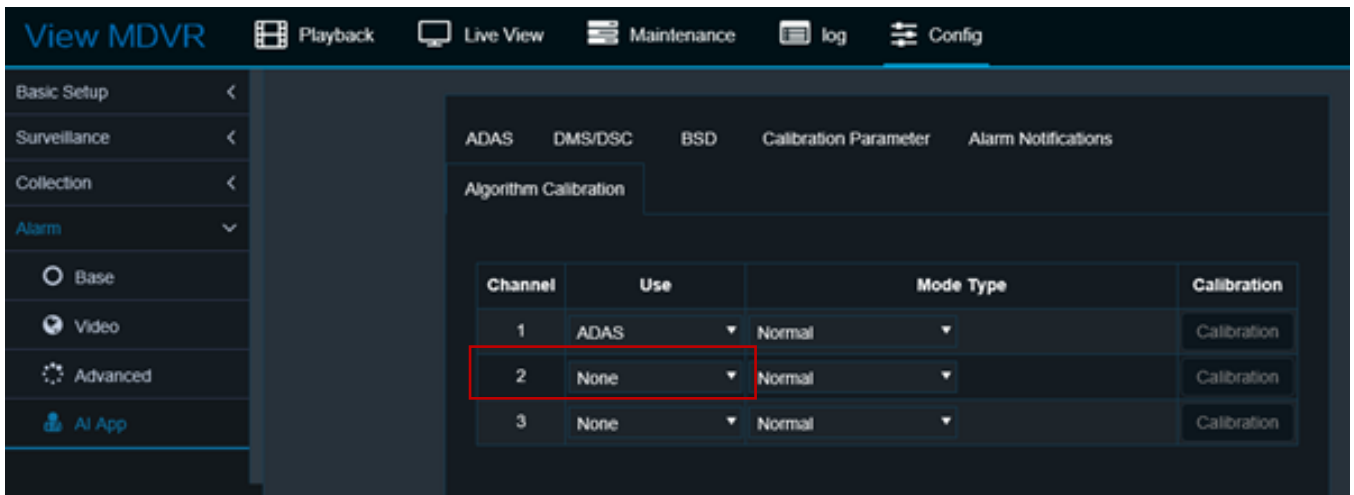

Figure 88: Select DSM calibration.

For Driver Camera Calibration you need to select the appropriate option based on the camera type.

- Dash mount Camera: Use **Front** option
- A-Pilar camera: Use **Side** option

2. With the App open, go to **Preview** and select **AI Calibration**

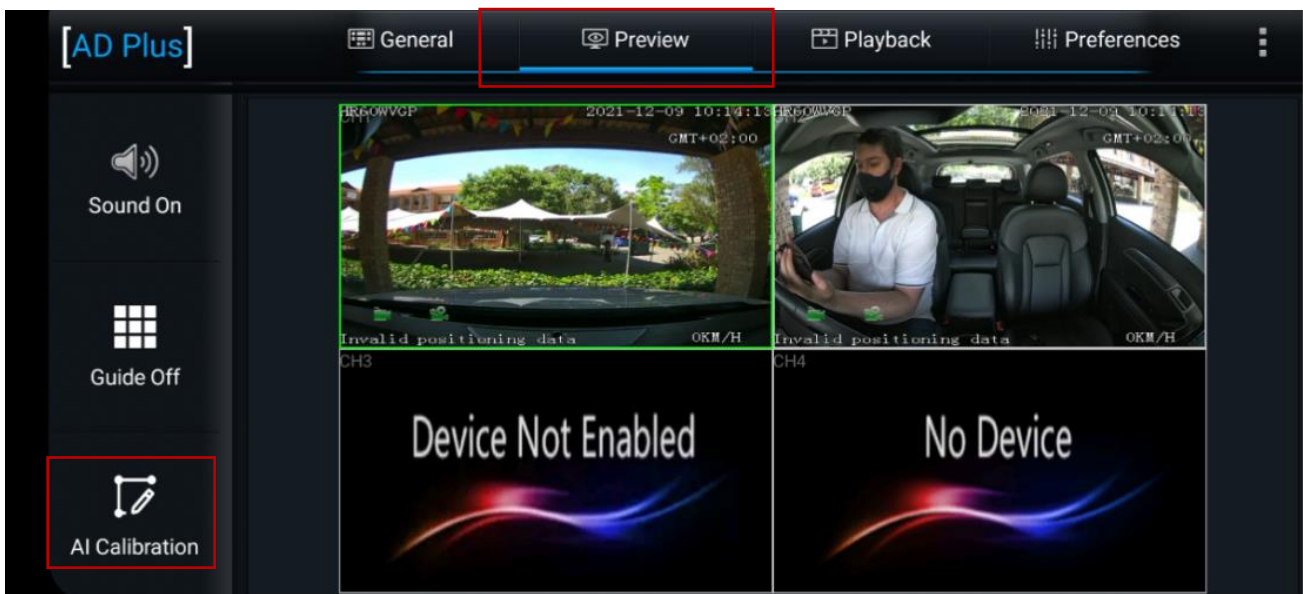

Figure 89: Select AI Calibration.

3. Select the DSM Calibration option

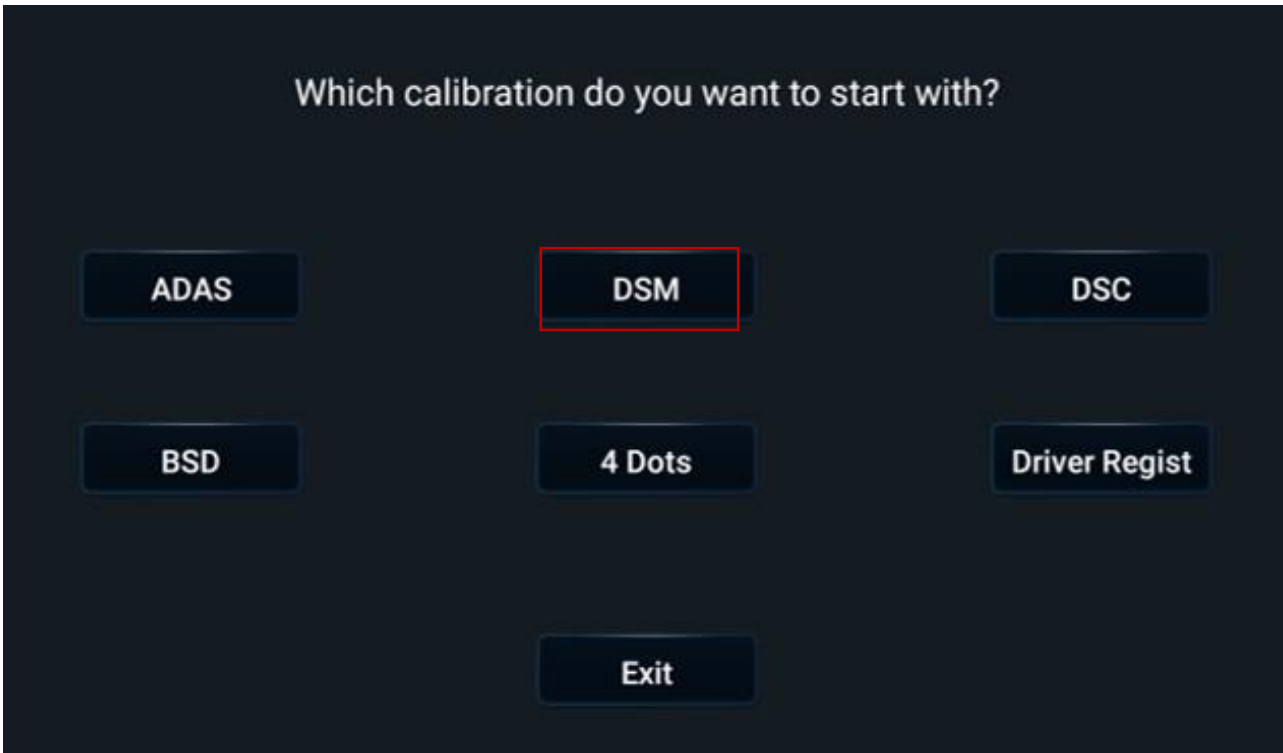

Figure 90: Select DSM (Driver Camera) Calibration.

4. Ensure correct camera is selected (3) and press Calibration



Figure 91: Select correct camera.

IMPORTANT - Please comply with 4.3.2

5. Review installation guidelines and press **Next**

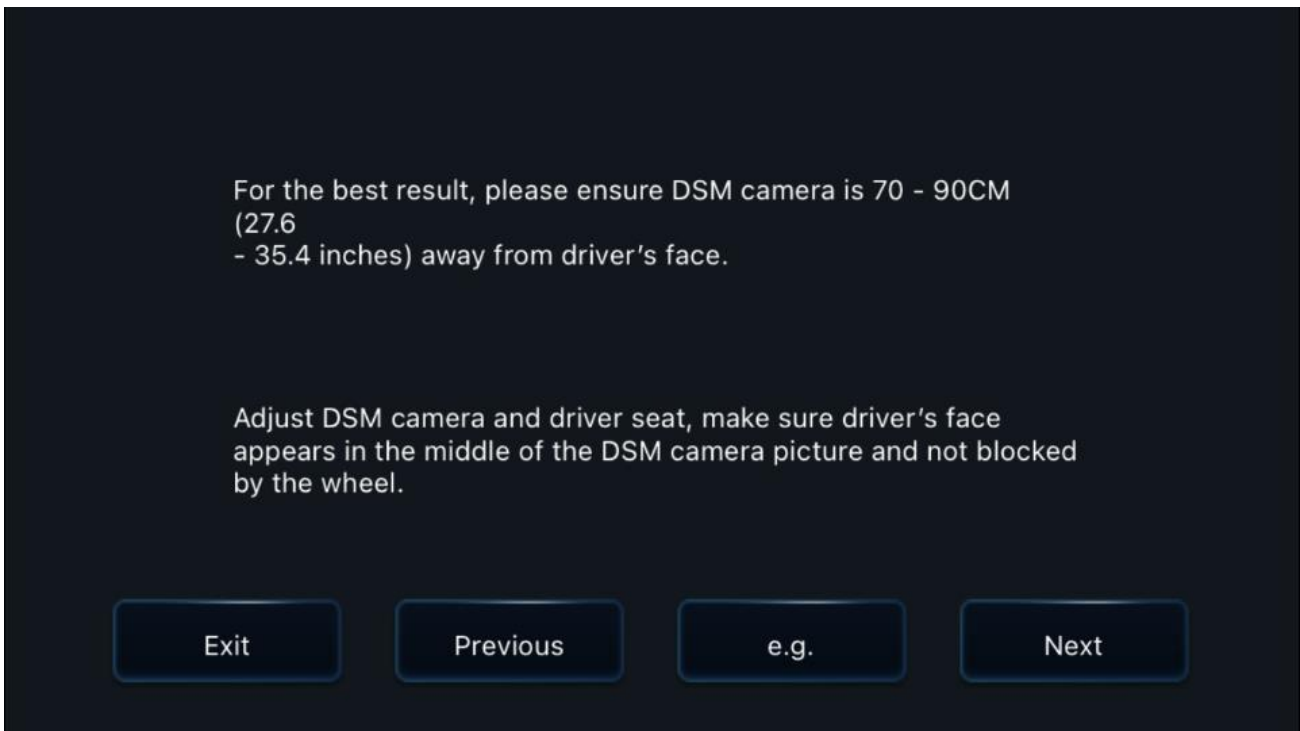

Figure 91: Select correct camera.

6. With the C29N the device will auto detect orientation and select installation location, select **Next**

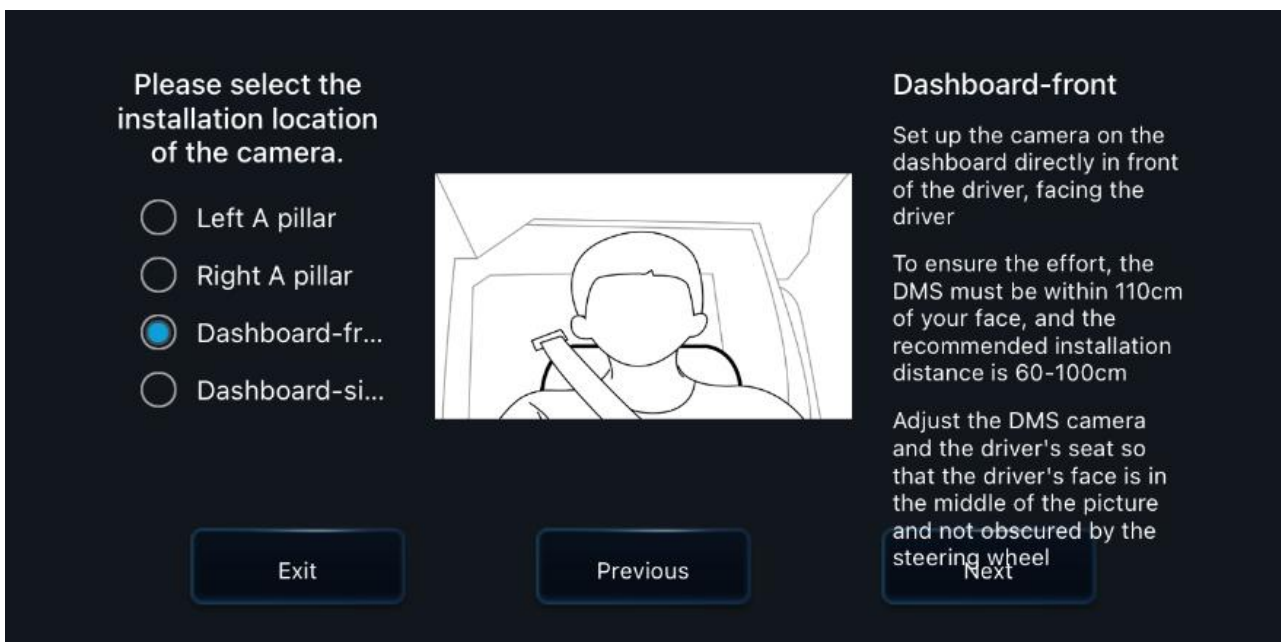
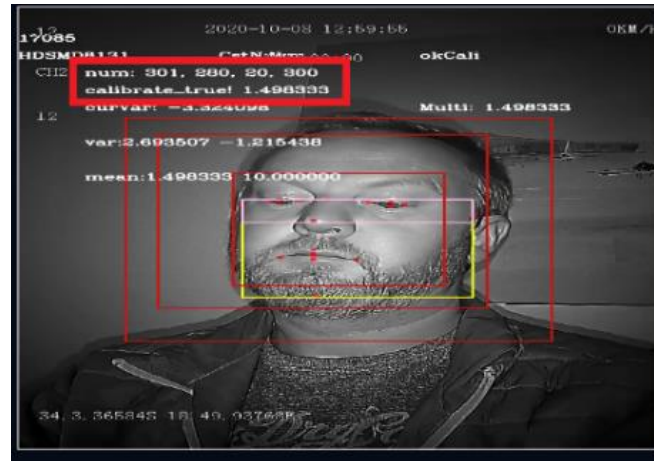

Figure 91: Select correct camera.

7. Calibration steps



For **Front** mounted calibration in order to get **CALIBRATION_TRUE** to show, the **calibrate: xx/50** score needs to be **51/50**. Press **Calibration** to complete calibration process.

For **Side** mounted calibration, the display must show **calibrate_true!** and **num:301,x,x,300**. Press **Calibration** to complete calibration process.

6 MiX Fleet Manager Setup

This section will guide you through the steps required on MiX Fleet Manager.

There are two ways to setup the AD Plus 2.0 on MiX Fleet Manager:

- Standalone device (without an OBC)
- Paired with an OBC (FM3xxx, MiX4000, MiX 6000 or MiX 6000 LTE)

Note: the artificial intelligence (AI) algorithms used to detect these events are probabilistic in nature. While extensive testing has been done to ensure their reliability, there is no guarantee that they will be 100% accurate.

6.1 VisionAI Standalone Setup

6.1.1 Enable Standalone Mobile device

When making use of a complete standalone solution you need to enable the Streamax Standalone mobile device.

- Click Manage.
- Under Config admin, click Libraries.
- Click on the Mobile Device library tab on the left.

- Search for the Streamax Standalone device.
- Click the downwards action arrow next to the device.
- Select Make available.

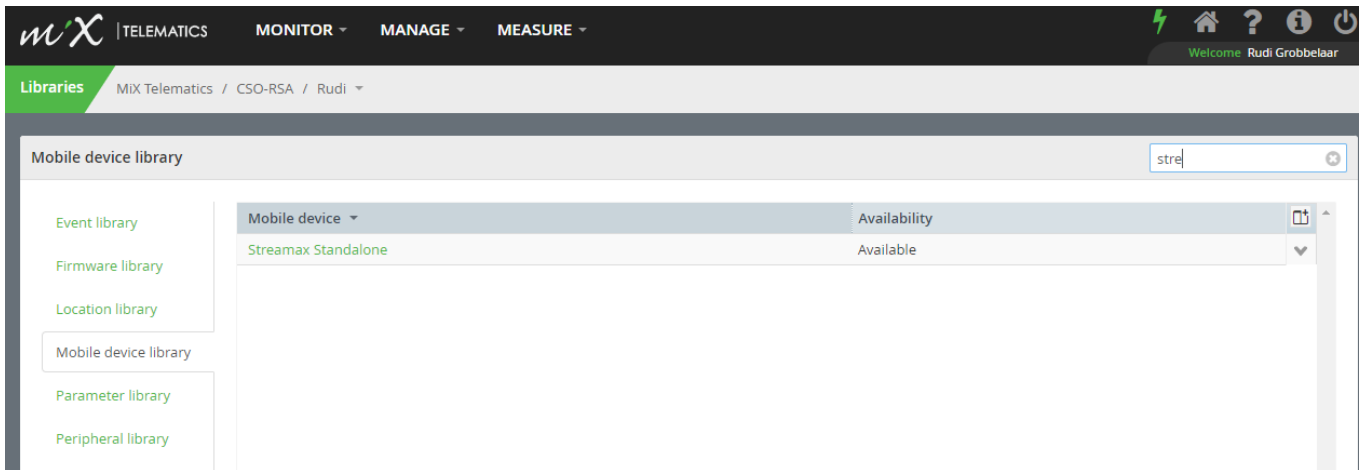

Figure 94: Selecting the Streamax standalone library.

A default Mobile device template and event template will be created.

6.1.2 Make the Peripheral device available

The VisionAI (AD Plus 2.0) device is listed in the peripheral as Streamax Camera.

- Click Manage.
- Under Config admin, click Libraries.
- Click on the Peripheral library tab on the left.
- Search for the **Streamax Camera** device.
- Click the downwards action arrow next to the device.
- Select Make available.

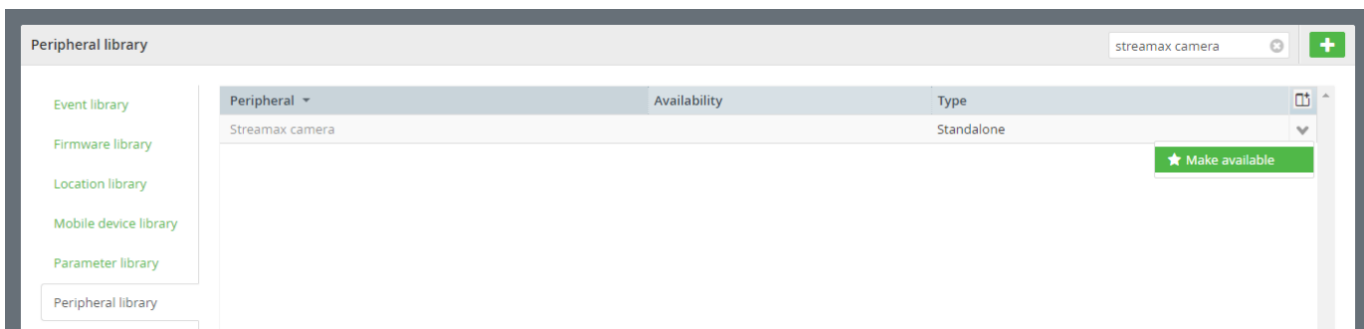

Figure 95: Making the Streamax standalone library available.

6.1.3 Make AI events available on your organization

The MiX Vision Events will automatically be made available as soon as the peripheral is enabled.

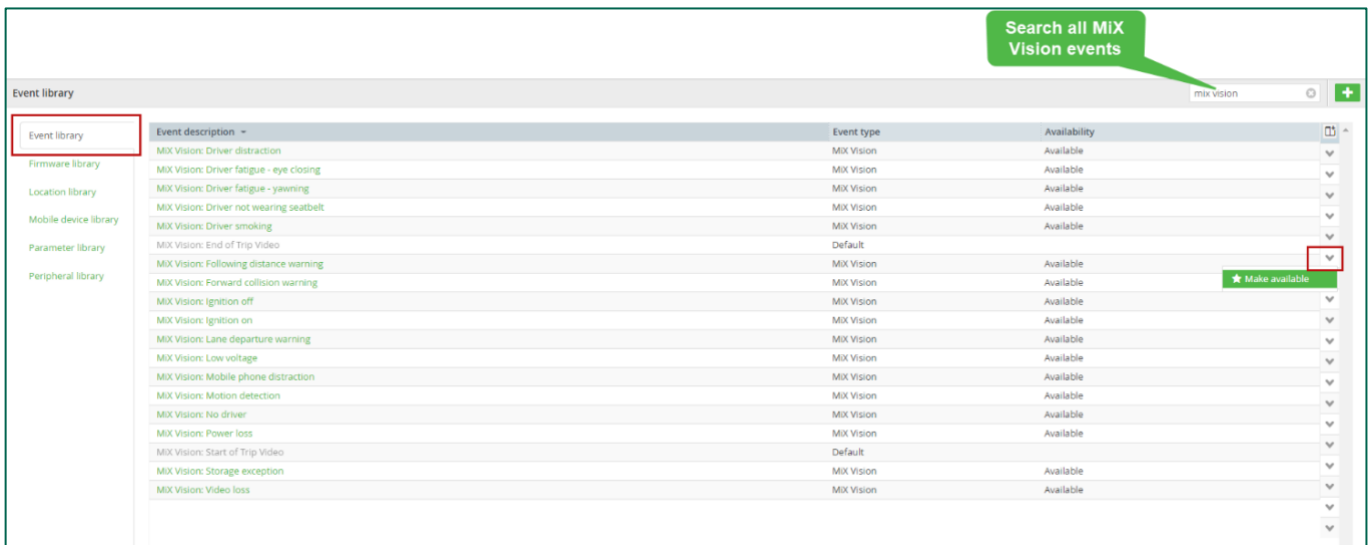

Figure 96: Selecting the VisionAI Events.

6.1.4 Connecting to the mobile device template (Standalone)

The MiX Vision AD Plus 2.0 device must be connected on the mobile device template. It is connected to the SP line, which is the connection for the new Standalone peripheral type.

- Click Manage.
- Under Config Admin, click Templates.
- Click on the Mobile device templates tab on the left.
- Select “Default mobile device template for Streamax Standalone”
- Click on SP line.
- By default, the Streamax C6D-AI device will be populated, click on it to change to Streamax Camera

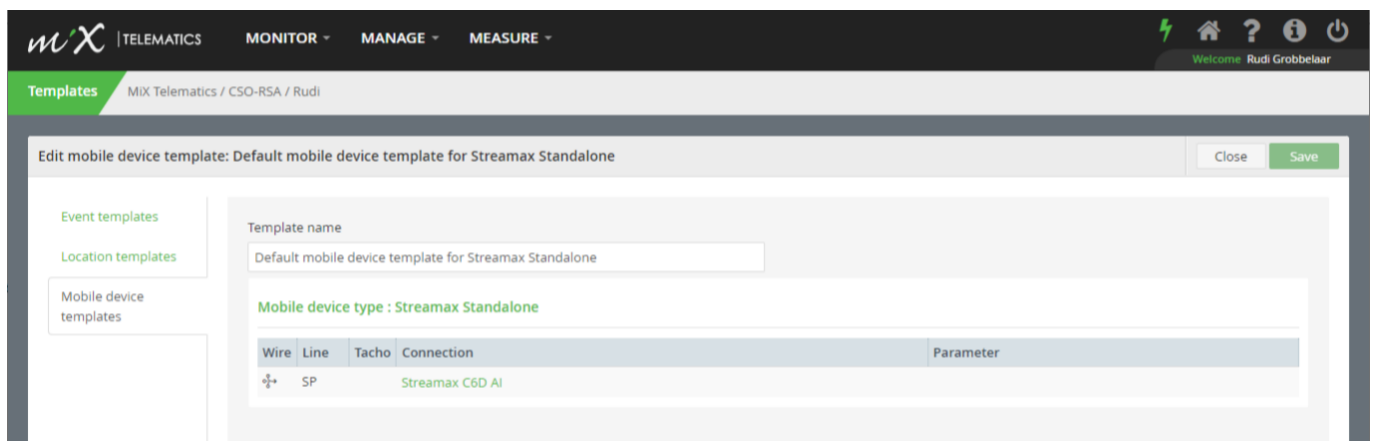

Figure 97: Connecting to the mobile device template.

6.1.5 Link device serial to your asset

When an asset is added to a configuration group with a connected AD Plus 2.0 peripheral, the details automatically appear on the asset's mobile device settings tab.

The MiX Vision AD Plus 2.0 10-digit serial number can be entered in the input box. This number is printed on the label of the AD Plus 2.0 device.

- Click Monitor.
- Under Fleet Admin, click Assets.
- Search for the relevant asset and click the green asset description link to edit the asset details.
- Click on the Mobile device settings tab on the left.
- Enter the 10-digit Streamax serial number in “Mobile device serial number” field.
- Save and exit

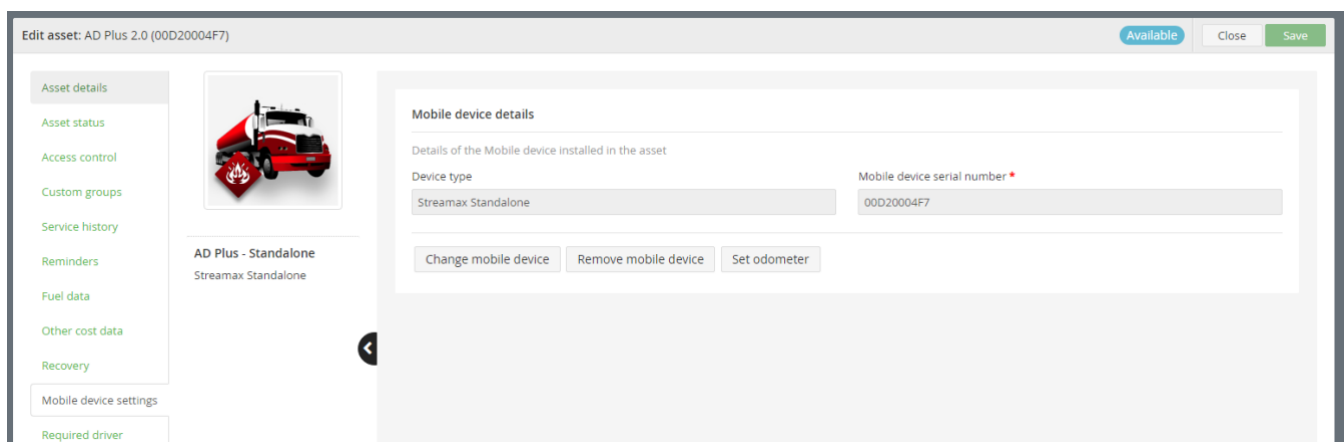

Figure 98: Entering Streamax serial number

6.1.6 Setting Harsh Driving and Overspeed events (standalone)

The AD Plus 2.0 device supports its own set of Driver behaviour events (see section 7.1.2, as well as an Overspeed event (see section 7.1.3).

They are not mapped to specific MIX AI Events in MiX Fleet Manager, but to the standard System events for Harsh Braking, Harsh Acceleration, Cornering and Overspeed. If it is requested to have these events available in MFM, just add the system events to the Event Template.

Remark: The event settings in the MFM, although available, are not used for event configuration for the VisionAI in standalone mode (setting the overspeed event in MFM to speed > 100km will not work, if the configuration in the device is set to > 80 km/h).

6.2 VisionAI with OBC setup

6.2.1 Make the Peripheral device available

The VisionAI (AD Plus 2.0) device is listed in the peripheral library.

- Click Manage.
- Under Config admin, click Libraries.
- Click on the Peripheral library tab on the left.
- Search for the Streamax Camera device.
- Click the downwards action arrow next to the device.
- Select Make available.

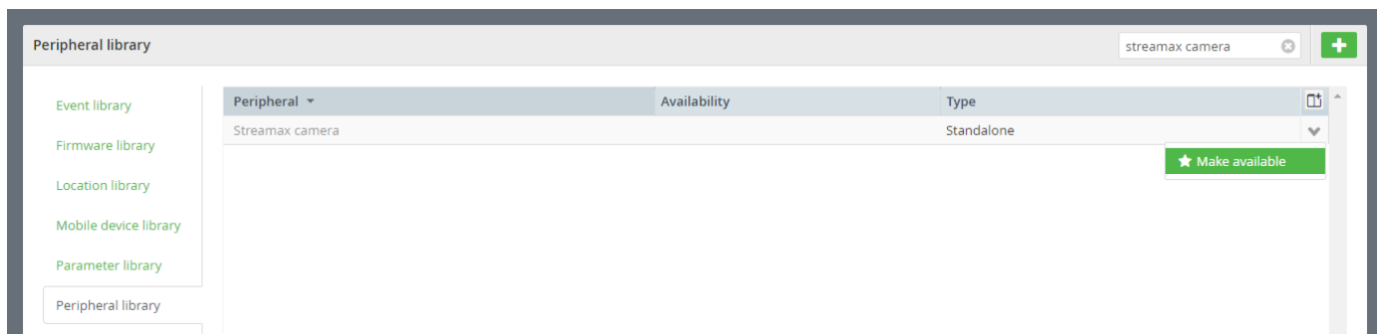

Figure 99: Making the Streamax standalone library available.

6.2.2 Make AI events available on your organization

The MiX Vision Events will automatically be made available as soon as the peripheral is enabled.

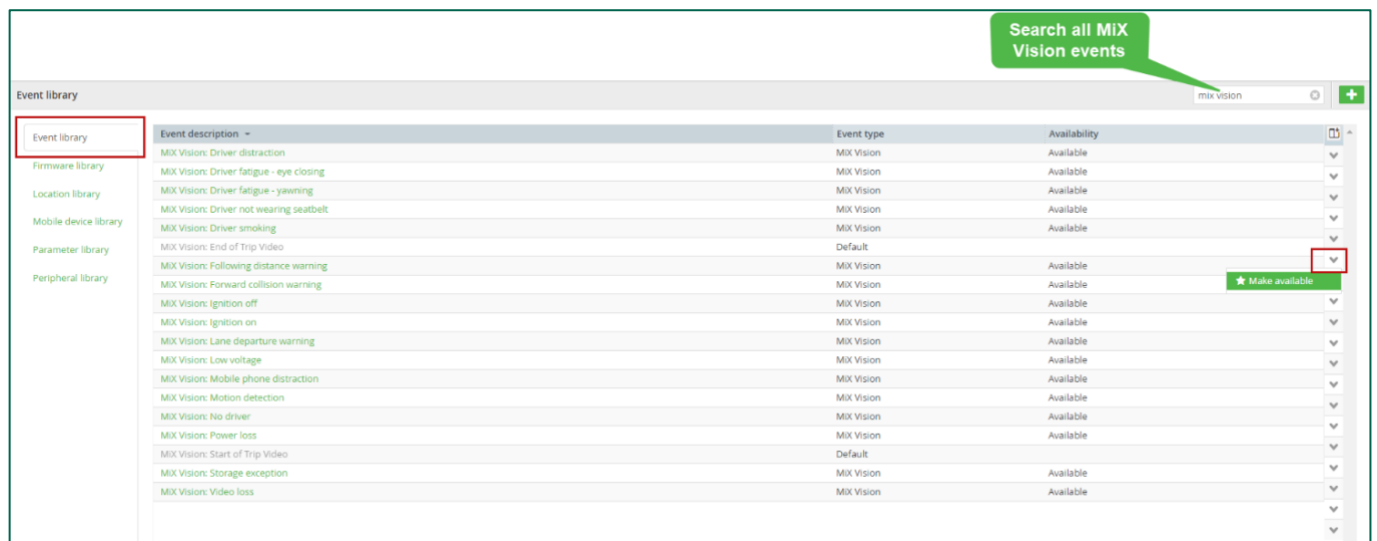

Figure 100: Selecting the VisionAI events.

6.2.3 Connecting to the mobile device template (OBC)

The MiX Vision AD Plus 2.0 device can be connected on the mobile device template. It is connected to the SP line. This type indicates that there is no direct communication between the camera unit and the on-board computer.

- Click Manage.
- Under Config Admin, click Templates.
- Click on the Mobile device templates tab on the left.
- Search for the relevant mobile device template in the list.
- Scroll down to the line connections and look for the SP line.
- Click on "not connected".
- Select the Streamax Camera (Standalone) device from the drop-down list of peripheral devices.
- Click Save.

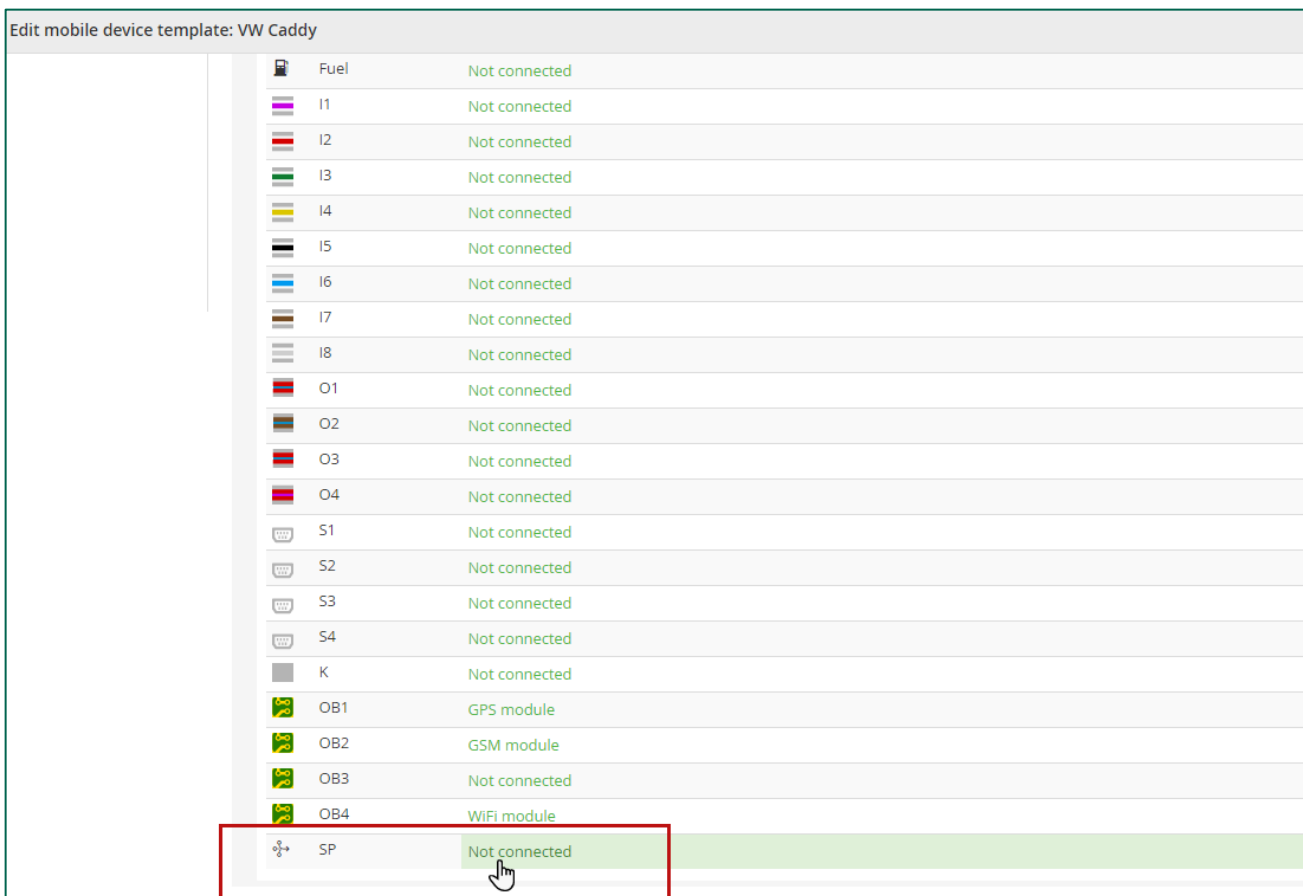

Figure 101: Configuring the mobile device template

Note: Only the MiX 4000, MiX 6000, MiX 6000LTE and FM units supports the AD Plus 2.0 devices.

6.2.4 Link device serial to your asset

Commission the VisionAI device using the mobile device settings page for the specific asset.

When an asset is added to a configuration group with a connected AD Plus 2.0 peripheral, the details automatically appear on the asset's mobile device settings tab.

The MiX Vision AD Plus 2.0 10-digit serial number can be entered in the input box. This number is printed on the device's label.

- Click Monitor.
- Under Fleet Admin, click Assets.
- Search for the relevant asset and click the green asset description link to edit the asset details.
- Click on the Mobile device settings tab on the left.
- Scroll down to the Streamax details section and enter the 10-digit Streamax serial number.
- Click Save

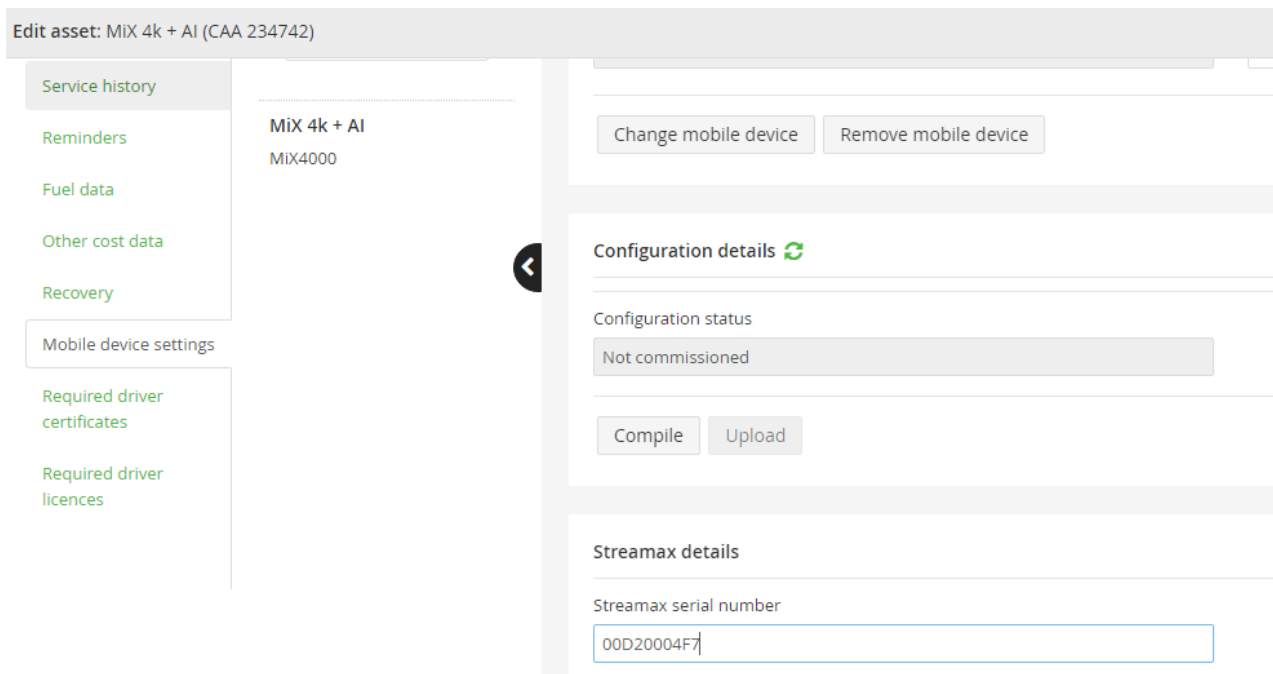

Figure 102: Linking OBC to VisionAI.

Upon saving this information, the device is set to commissioned in MiX Fleet Manager and events that are configured to record video in the event template will then have video associated.

After commissioning the device, it will no longer be possible to edit the serial number, but the device can be changed or removed.

Please note, if a MiX Vision 1 script is associated to the mobile device template that is linked to the asset's configuration group, the VisionAI details section will not be visible.

6.3 Record video for OBC events

You can enable video recording on a mobile device generated event in the event template on the event configuration page or on a specific event when using the VisionAI device. This is only supported when the AD Plus 2.0 is connected to a MiX OBC.

This is only available on Detailed and Notification events.

- Click Manage.
- Under Config admin, click Templates.
- Make sure Event templates are selected on the left.
- Search for the relevant template.

TIP: If you are looking for the event template of a specific asset, go to the Configuration groups menu under Config Admin, search for the asset and scroll to the left to view the asset's mobile device template and event template. Clicking the template will take you straight to the template's settings.

- Click the downwards arrow and select Edit.
- Scroll to the list of events that have been selected on the template (or select new events by clicking the Select events button.)
- Click on the green hyperlinked event, e.g., panic button pressed.

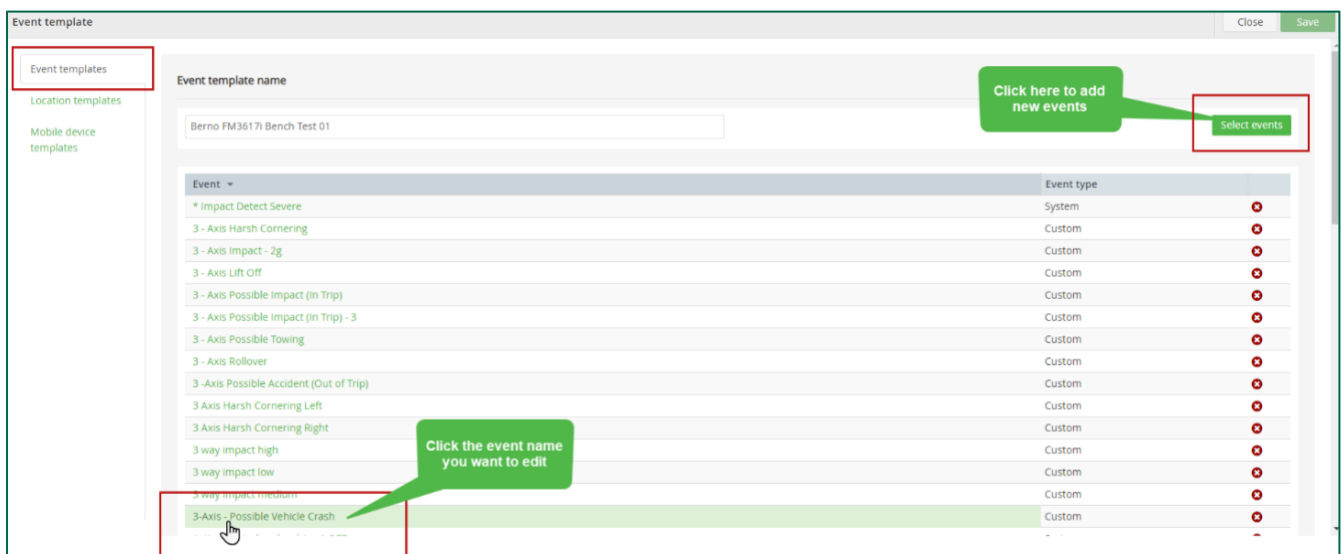

Figure 103: Adding and editing video events.

- Scroll down to the Record section.
- Enable recording of the event by checking the box next to Record event.
- Check the box next to Record video.
- Video recording cannot be enabled for summarised events

Templates MIX Telematics / QA Team / QA Live Vehicles

Edit event template: R1 FM 3316 Panic MIX Vision

Record

1 Record event

Record delay: 0 : 0 : 0
Hours Minutes Seconds
 Recording type: Detailed
Records the start and end of each occurrence of the event.

Record actions

Start odometer End odometer

Start position End position

2 Record video

Record pulse count (fuel etc.)

Figure 104: Saving Events.

1. Click **Save**.

The event needs to be compiled and uploaded to the OBC's configuration as it is mobile device generated using the compile config feature.

When the trip is processed. the video footage is retrieved from the VisionAI Server for the date and time that the event occurred and is then associated to the event in MiX Fleet Manager.

7 Advanced Settings

7.1 Standalone settings

The MiX Vision AD Plus 2.0 can be setup to generate the following OBC parameters:

- AVL rate
- Harsh Driving Events (Braking/Acceleration/Cornering)
- Overspeeding

7.1.1 AVL Rate

There are three sections that can be used for AVL rate on the device. By default, only Constant Upload (every 30s) and GPS Heading Change is used.

- Constant Upload Mode: Fixed Time and distance interval upload
- Variable Upload Mode: Speed based interval and distance upload
- GPS Heading Change: Angle deviation upload

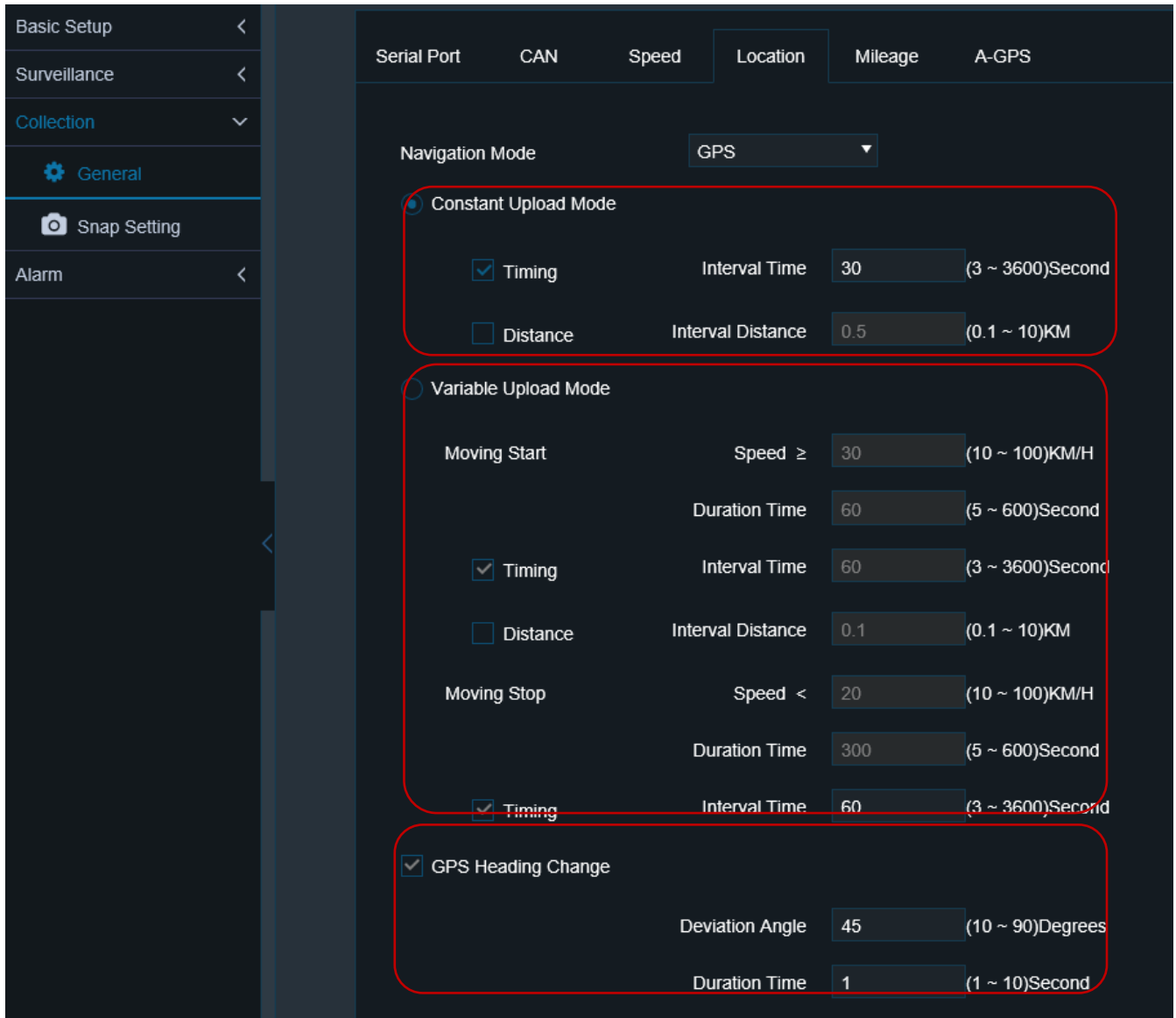

Basic Setup <

Surveillance <

Collection v

General

Snap Setting

Alarm <

Serial Port CAN Speed Location Mileage A-GPS

Navigation Mode GPS

Constant Upload Mode

Timing Interval Time 30 (3 ~ 3600)Second

Distance Interval Distance 0.5 (0.1 ~ 10)KM

Variable Upload Mode

Moving Start Speed ≥ 30 (10 ~ 100)KM/H

Duration Time 60 (5 ~ 600)Second

Timing Interval Time 60 (3 ~ 3600)Second

Distance Interval Distance 0.1 (0.1 ~ 10)KM

Moving Stop Speed < 20 (10 ~ 100)KM/H

Duration Time 300 (5 ~ 600)Second

Timing Interval Time 60 (3 ~ 3600)Second

GPS Heading Change

Deviation Angle 45 (10 ~ 90)Degrees

Duration Time 1 (1 ~ 10)Second

Figure 105: AVL rate settings.

Section	Subsection1	Subsection2	Explanation
Constant Mode Upload	Timing		every x-seconds a position is sent
	Distance		every x-km a position is sent
Variable Upload Mode	Moving Start	Speed	Active above speed value
		Duration	Keep the condition for x seconds you will move to moving start/ moving stop/ deviation angle status
	Timing	Interval Time	every x-seconds a position is sent for "Moving Start Speed"
	Distance	Interval Distance	every x-km a position is sent for "Moving Start Speed"
	Moving Stop	Speed	Active below speed limit
		Duration Time	Keep the condition for x seconds you will move to moving start/ moving stop/ deviation angle status
	Timing	Interval Timing	every x-seconds a position is sent for "Moving Stop Speed"
GPS Heading Change	Deviation Angle		Angle deviation when a position will be sent
	Duration Time		Keep the condition for x seconds you will move to moving start/ moving stop/ deviation angle status

7.1.2 Harsh Driving Events (Braking/Acceleration/Cornering)

You can enable Harsh driving events via Config > Alarm > Advanced > Driver Behaviour Alarm

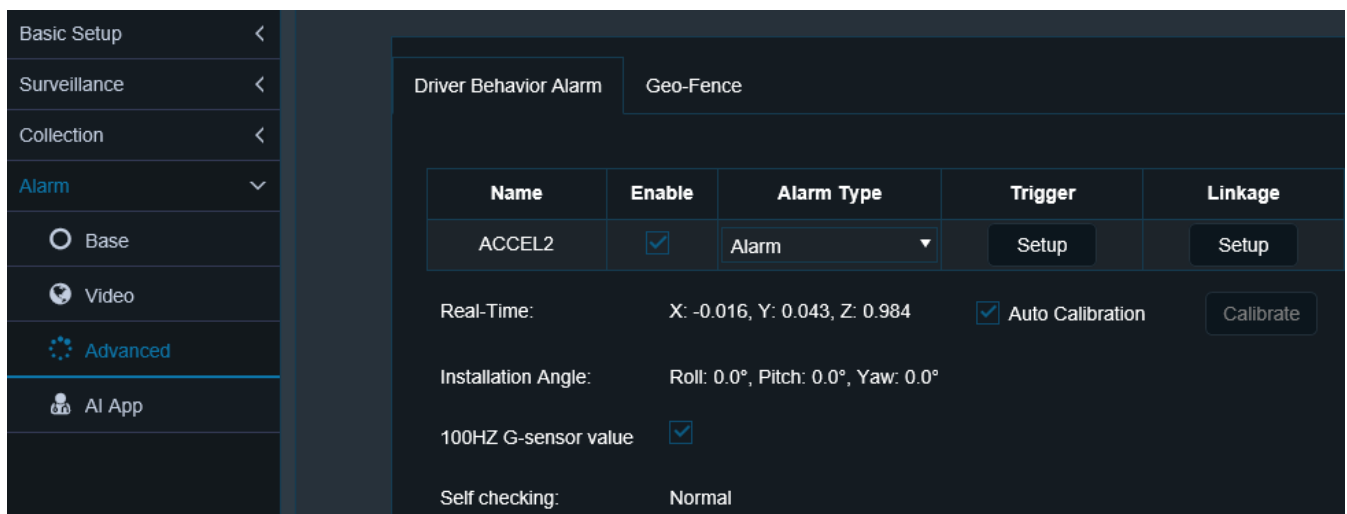

Figure 106- Enabling Driving Behaviour alarm

- 100HZ: Check the 100HZ G-sensor value. ACC is two packages per second, 50 entries each package

Offset is the acceleration from the resultant force in a certain axis direction. If the acceleration in the direction is greater than this value, an alarm will be triggered

- Harsh Braking: negative value in the x-axis.
- Hard Acc: positive value in the x-axis.
- Harsh Left Turn: positive value in the y-axis.
- Harsh Right Turn: negative value in the y-axis.
- Effective Time: a time period during which a cleared alarm is triggered again. Alarms triggered in this period are considered the same.
- Speed is the range at which the algorithm will be active.

Note difference to MiX OBC i.e., accelerometer vs GPS, which is noisier so not directly comparable to a MiX OBC

ACCEL2 Trigger

Alarm Name	Enable	Offset	Speed
Harsh Braking	<input checked="" type="checkbox"/>	0.304 (0.001 ~ 1)	0 ~ 200 (0~200)KM/H
Hard Acceleration	<input checked="" type="checkbox"/>	0.124 (0.001 ~ 1)	0 ~ 200 (0~200)KM/H
Harsh Left Turn	<input checked="" type="checkbox"/>	0.35 (0.001 ~ 1)	0 ~ 200 (0~200)KM/H
Harsh Right Turn	<input checked="" type="checkbox"/>	0.35 (0.001 ~ 1)	0 ~ 200 (0~200)KM/H
Shock	<input checked="" type="checkbox"/>	X: 1 (0.1 ~ 8) Y: 1 (0.1 ~ 8) Z: 2 (0.1 ~ 8)	
Effective Time		10 (0 ~ 10)Second	
Recommended Setting		<div style="border: 1px solid white; padding: 5px; display: inline-block; margin: 5px;">Light Duty</div> ≤ 6 tons	<div style="border: 1px solid white; padding: 5px; display: inline-block; margin: 5px;">Medium Duty</div> ≤ 14 tons
			<div style="border: 1px solid white; padding: 5px; display: inline-block; margin: 5px;">Heavy Duty</div> > 14 tons

Cancel

OK

Figure 107: Driver behaviour settings.

Default Settings:

The recommended values can be set according to three types of vehicles: Light Duty, Medium Duty, and Heavy Duty. Tap the corresponding button and the recommended values will be filled in automatically.

Recommended Setting

The Light/Medium/Heavy Duty parameters shown below

A good starting point for Light vehicles in the last column "Custom"

Event	Light Duty	Medium Duty	Heavy Duty	Custom
Harsh Braking	0.5	0.4	0.4	0.304
Hard Acceleration	0.3	0.25	0.25	0.124
Harsh Left Turn	0.35	0.35	0.35	0.35
Harsh Right turn	0.4	0.35	0.35	0.35

7.1.3 Overspeed

The combination of Speed and Duration is used to trigger the speed alarm, that is, when the speed exceeds the set speed for a certain period of time, it is considered as a speeding alarm.

Config > Alarm > Base > Speed Alarm

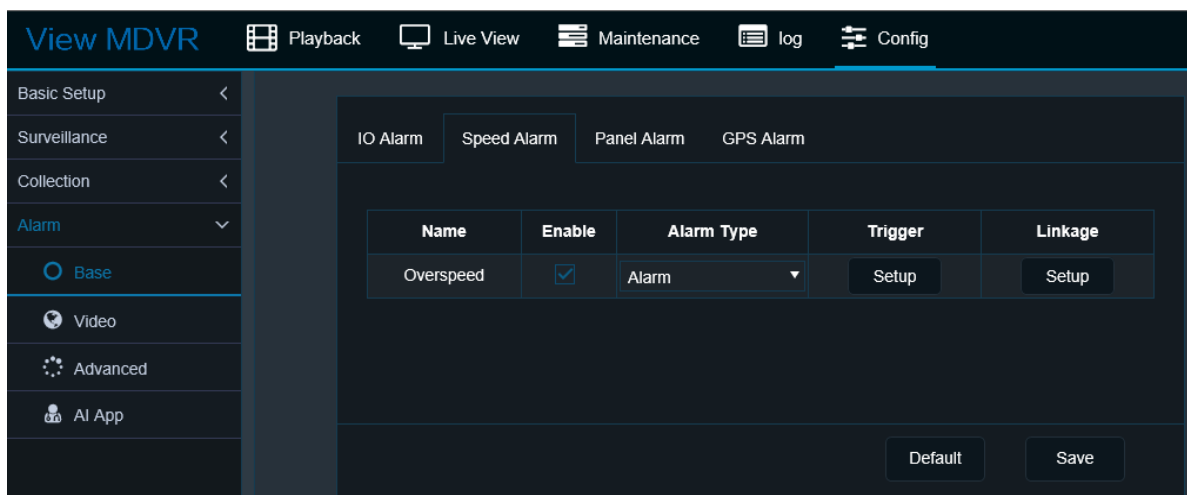
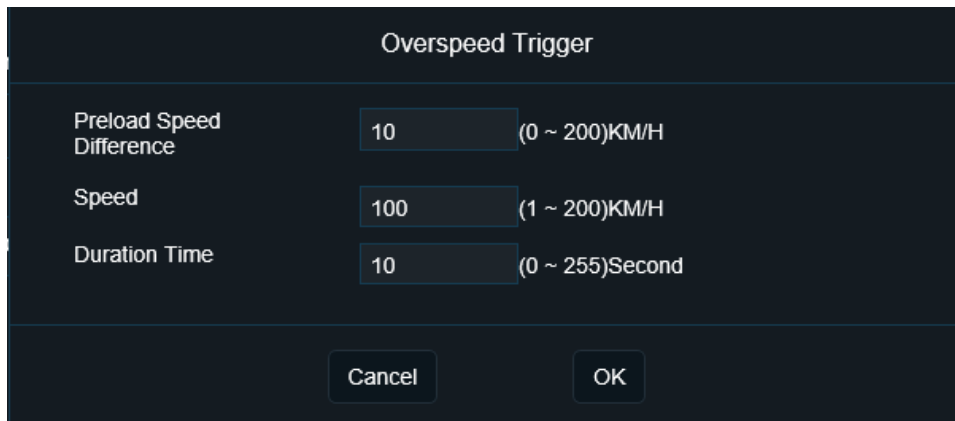

Figure 1: Enabling Overspeed alarm.

Trigger Settings:



Overspeed Trigger		
Preload Speed Difference	10	(0 ~ 200)KM/H
Speed	100	(1 ~ 200)KM/H
Duration Time	10	(0 ~ 255)Second
Cancel OK		

Figure 2: Overspeed alarm settings.

- *Preload Speed Difference* is a value for speed warning. For example, the speed threshold is 100 and the warning speed difference is 10, when the speed reaches 90, a voice alarm will be triggered.
- *Speed*: Selected speed value to use.
- *Effective Time*: a time period during which a cleared alarm is triggered again. Alarms triggered in this period are considered the same and no voice or alarm will be triggered.

7.2 Flight Mode

Flight mode can be enabled via I/O line to switch off all radios (LTE Modem, GPS, Bluetooth, Wi-Fi) when required. During this mode all the radios will be off, but the device will still operate as normal generating alarms and saving videos.

When in Flight mode, the “earth” icon will flash red on the unit. Once disabled it switches off again and normal operation continues (about 2min).

NOTE: Currently there is no visibility in MiX Fleet Manager if unit has been placed in Flight mode

NOTE: If you do not deactivate Flight mode and I/O line remains high, unit will remain in flight mode even after reboot.



Figure 3: VisionAI LED panel indicating Flight Mode.

1. In the I/O configuration interface (**Config > Alarm > Base > IO Alarm**), select the corresponding "Sensor Uses" parameter as "Flight Mode"

2. The trigger of the corresponding IO can be selected as low or high in Trigger Settings.
3. If the IO trigger mode is selected as high, when the IO signal is given a high level, the flight mode will be triggered. At this time, the communication modules enter the flight mode, turning off LTE, WIFI and Bluetooth.
4. If the IO trigger mode is selected as high, when the IO signal switches from high to low, the communication module will return to normal mode, and the LTE, WIFI and Bluetooth module will return to the original state (restore time less than 2min) and all GPS and event data will be sent to the server that occurred during flight mode.
5. Enable/Disable Flight Mode, record log " Enable/Disable Flight Mode "
6. Enter the flight mode successfully, record the log "enter the flight mode successfully", otherwise record "enter the flight mode failed"

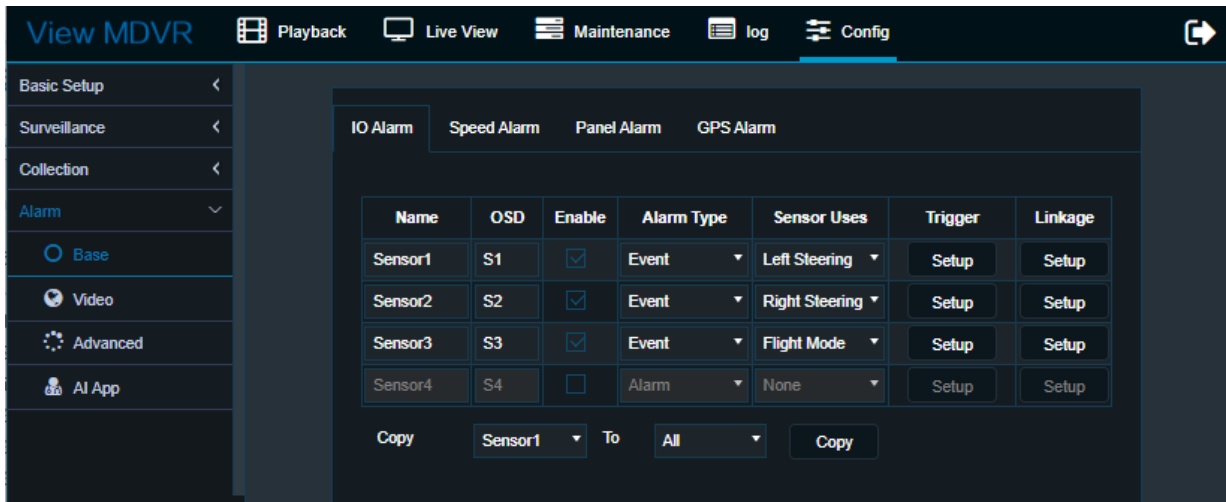

Figure 4: Setting flight mode using input line.

7.3 Privacy Mode

Privacy mode can be enabled to stop recording on pre-configured channels. Channels that are not set for privacy mode will be recorded. There are two methods to set Privacy mode: using an I/O line or the button available on the device. When in Privacy Mode, the Recording Status LED will turn solid RED. Once disabled, normal recording resumes.

NOTE: Currently there is no visibility in MiX Fleet Manager if unit has been placed in Privacy mode

NOTE: If you do not deactivate privacy mode, the device will remain in privacy mode even after reboot.

NOTE: If Privacy mode is enabled, only the channels will be switched off, GPS data will still work as normal generating trips

For configuring the Privacy Mode go to **Config > Alarm > Video > Privacy Mode**

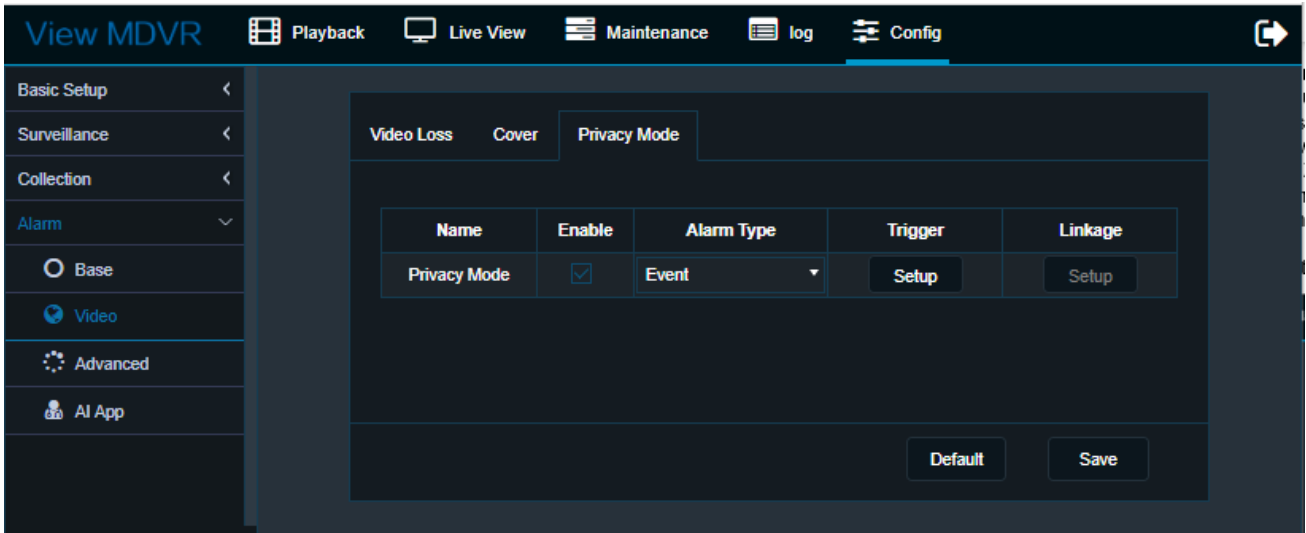

Figure 5: Enabling Privacy Mode.

The following configurations must be set:

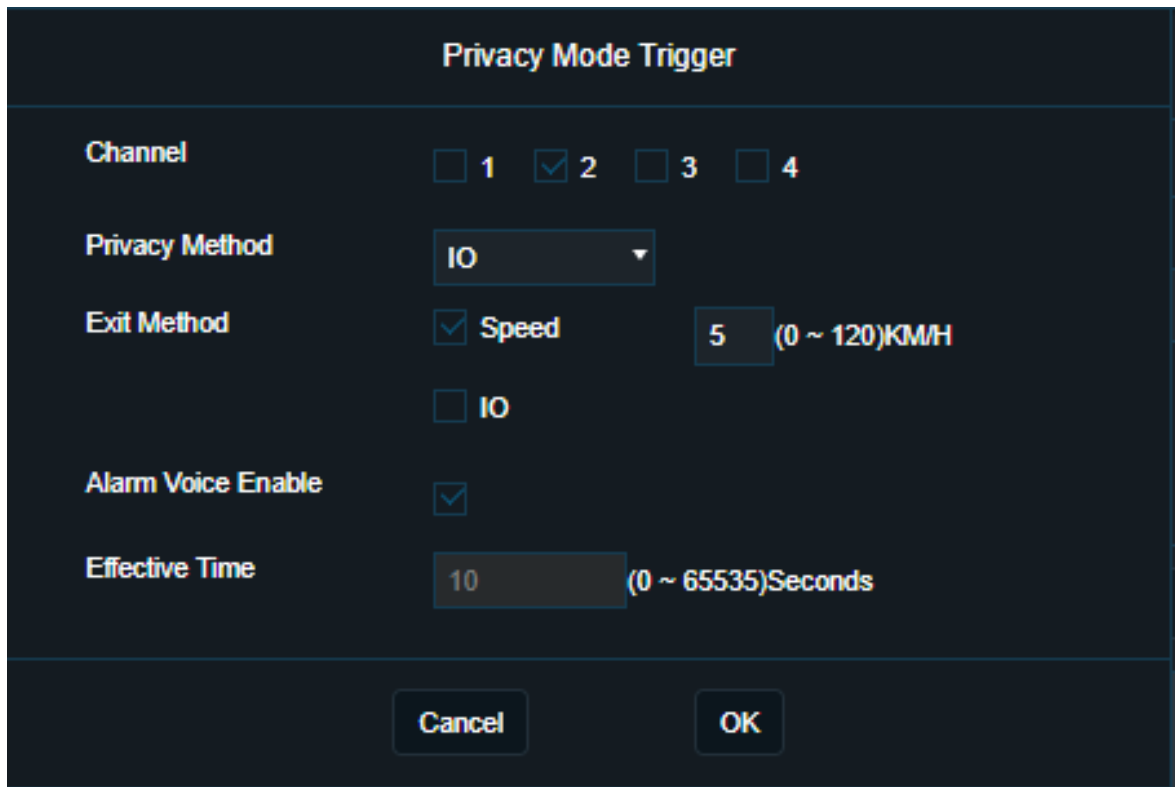

Figure 6: Privacy Mode settings.

- Channel: selected which channels will be turned off during Privacy Mode
- Privacy Method: define how the privacy mode should be activated using I/O Line or ACC (ignition – do not use)
- Exit Method: define how the privacy mode is deactivated (speed or I/O Line)
- Alarm Voice Enabled; Enables Voice prompt

7.3.1 Function Button Method



Figure 7: VisionAI LED panel indicating Privacy Mode.

- **Activate:** Pressing the button once for more than 2 seconds turns on the privacy mode (stop video/audio recording).
- **Deactivate:** Pressing the function button once for more than 2 seconds turns off the privacy mode (resume video/audio recording).

7.3.2 I/O Line method

- In the I/O configuration interface (**Config > Alarm > Base > IO Alarm**), select the corresponding "Sensor Uses" parameter as "Privacy"

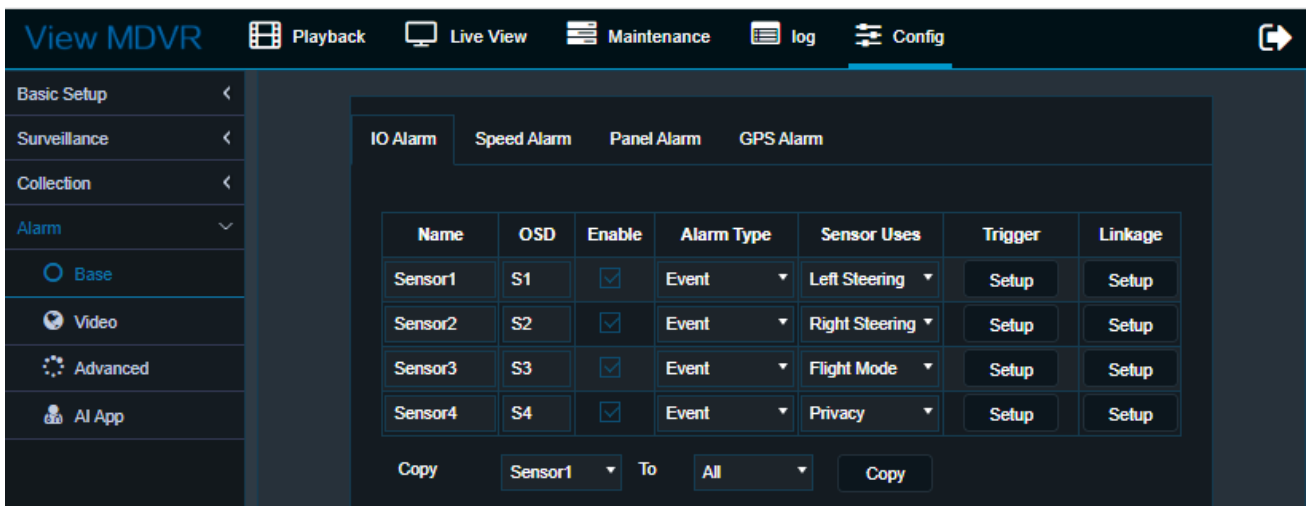

Figure 8: assigning the I/O line to Privacy Mode.

- The trigger of the corresponding IO can be selected as low or high in Trigger Settings.

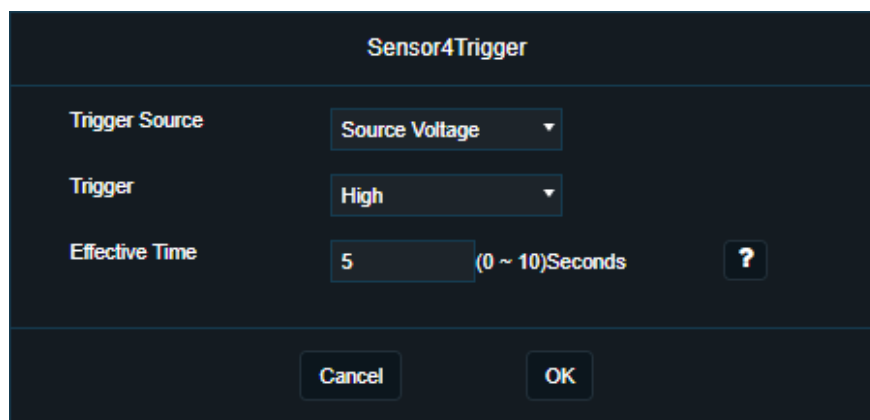

Figure 9: Configuring Trigger condition for Privacy Mode.

- If the IO trigger mode is selected as high, when the IO signal is given a high level, the Privacy mode will be triggered.

7.4 SMS commands

In some cases when incorrect settings were accidentally applied to a unit like APN settings, it is possible to send SMS to the device with the correct settings.

- Device needs to be online for SMS to be received.
- Please do not forget the “!” at the end of the string.
- If you make an error, an error message will be sent back.

Each section has a unique identifier and structure shown on each section below.

7.4.1 APN setting change

Only APN name can be set and not username and password.

Identifier: SAPN

Structure: 99+username,+password,+SAPN+(APNname)!

- **Example:** 99admin,admin,SAPNinternet!
 - Result: “internet” APN programmed

7.4.2 Server Setting change

Maximum of 2 servers can be set via SMS command.

Identifier: SMCM

Structure: 99+username,+password,+SMCM+server1+enable/disable,+Enable,+N9M Register Server,+N9M Media Server,+N9M Register Server Port, server2+enable/disable,+Enable,+N9M Register Server,+N9M Media Server,+N9M Register Server Port!

- **Example:** 99admin,admin,SMCM1,stm.au.mixel.com,stm.au.mixel.com,20001,20001!
 - Result: server1 set to stm.au.mixel.com
- **Example:**
99admin,admin,SMCM1,stm.au.mixel.com,stm.au.mixel.com,20001,20001,2,1,stm.za.mixel.com,stm.za.mixel.com,20001,20001!
 - Result: server1 set to stm.au.mixel.com and server2 set to stm.za.mixel.com

7.4.3 Wi-Fi settings change

You can enable or disable Wi-Fi via SMS command and also select what mode (Client/AP) the Wi-Fi needs to be. The identifier is one of 3 Mode selections

- WIFIO = Disable (*Capital letter "O" and not number zero*)
- WIFI1 = Client Mode
- WIFI2 = AP Mode

7.4.3.1 Disable Wi-Fi

Structure: 99+username,+password,+Mode,+!

- **Example:** 99admin,admin,WIFIO!
 - Result: disable Wi-Fi

7.4.3.2 Client Mode

Structure: 99+username,+password,+Mode,+EncryptionType,+ESSID,+password,StaticDynamicIP,+!

StaticDynamicIP: 0 = static IP; 1 = dynamic IP.

- **Example:** 99admin,admin,WIFI1,WEP,streamax,streamax,1!
 - Result: Wi-Fi set to Client mode with WEP encryption, ESSID and password set to "Streamax" with dynamic IP address
- **Example:** 99admin,120223,WIFI1,WPA/WPA2-PSK,streamax,streamax,1!
 - Result: Wi-Fi set to Client mode with WPA/WPA2-PSK encryption, ESSID and password set to "Streamax" with dynamic IP address
- **Example:** 99admin,120223,WIFI1,WPA2.ENTERPRISE,streamax,streamax,streamax,1!
 - Result: Wi-Fi set to Client mode with WPA2.ENTERPRISE encryption, ESSID and password set to "Streamax" with dynamic IP address

7.4.3.3 AP Mode

Structure: 99+username,+password,+Mode,+EncryptionType,+ESSID,+password,+enable/disable+!

- **Example:** 99admin,admin,WIFI2,WPA,streamax,streamax,1!
 - Result: Wi-Fi set to AP mode with WPA encryption, ESSID and password set to "streamax"
- **Example:** 99admin,120223,WIFI2,WEP,streamax,streamax,1!
 - Result: Wi-Fi set to AP mode with WEP encryption, ESSID and password set to "streamax".
- **Example:** 99admin,120223,WIFI2,NONE,streamax,1!
 - Result: Wi-Fi set to AP mode with No encryption, ESSID set to "streamax" and no password.

8 Log Your Work

Double check the installation quality and confirm there are no abnormalities.

- Check that the parameter settings have been saved and take a screenshot.
- Capture a video of the video image quality.

Take a picture of all the equipment and of the entire operation after installation is completed.

- Take a picture of all camera locations.
- Take a picture of cab after installation.

Photos and screenshots must be taken during installation for subsequent operations and maintenance tracking.

- Collecting Vehicle Information
 - Includes the appearance of the car, driving cockpit before installation, and vehicle information plate
- Equipment location in cab after installation
- Position of the anchored Main unit and connected wiring
- Software version status

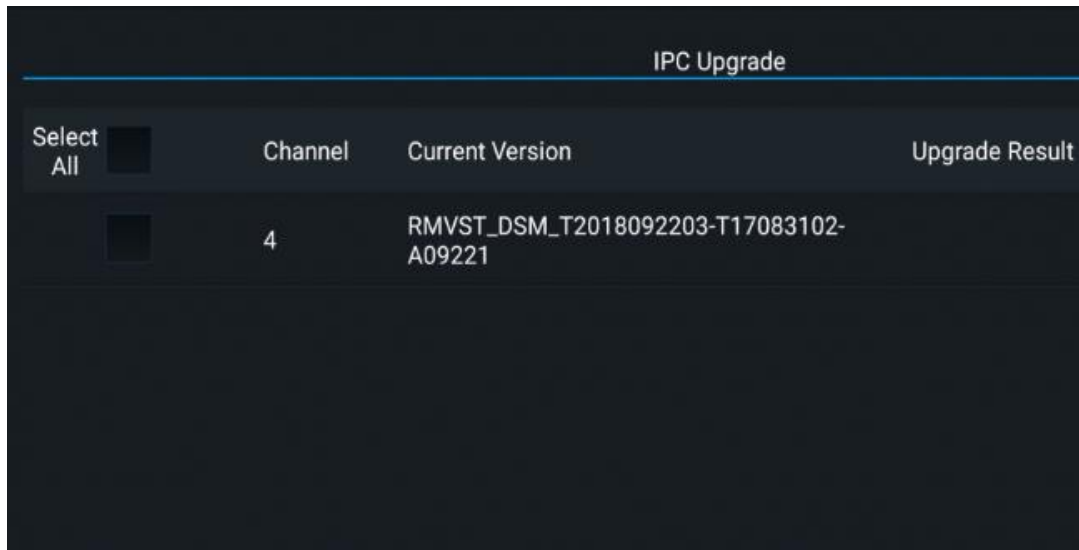
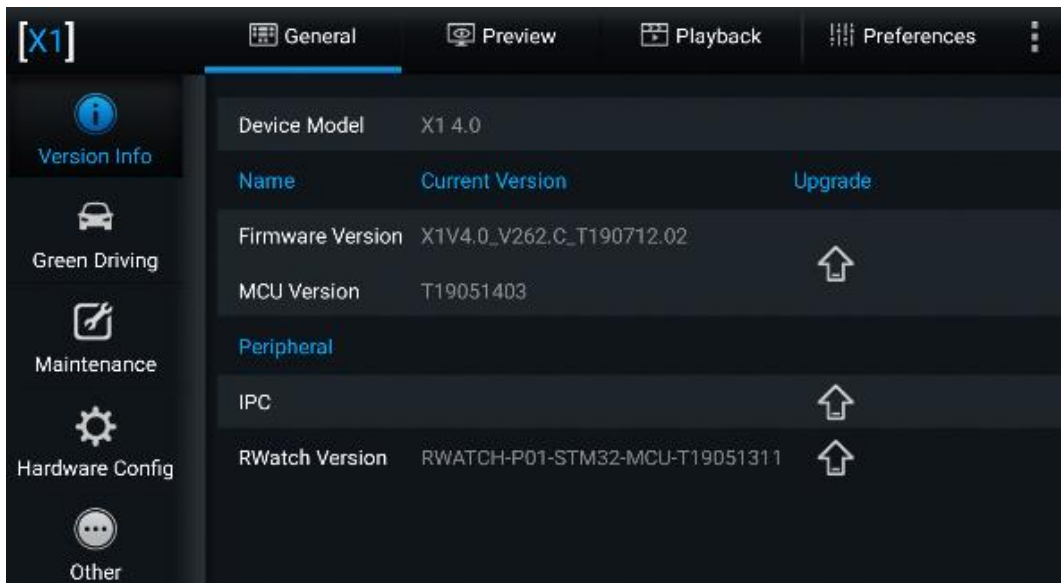

Figure 10: Software version Screenshots

Screenshot showing Driver Camera calibration

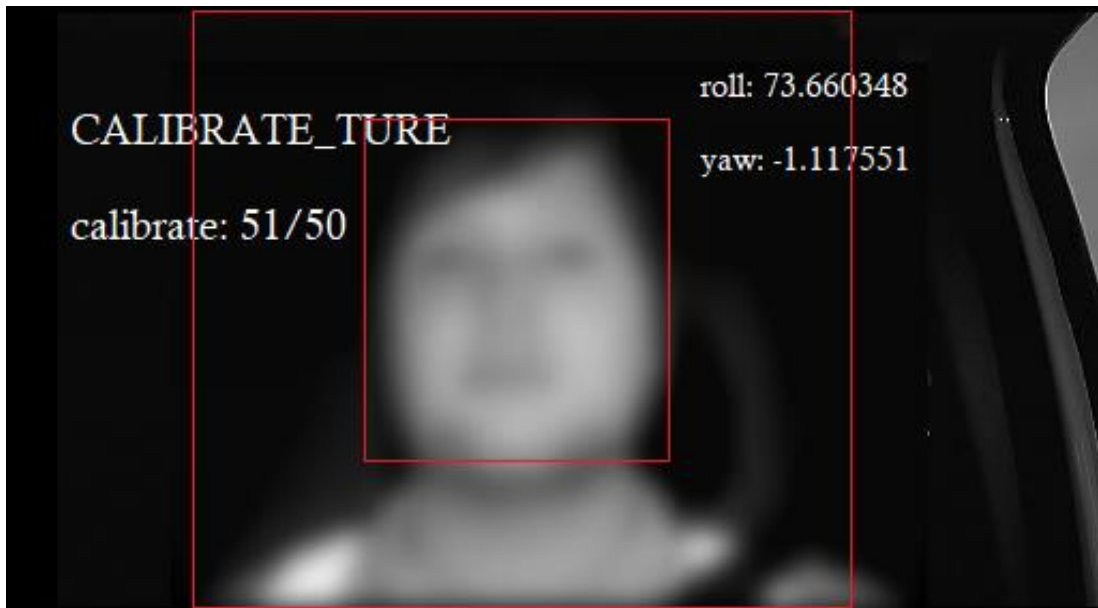

Figure 11: Screenshot of Driver Camera Calibration.

Speed source settings

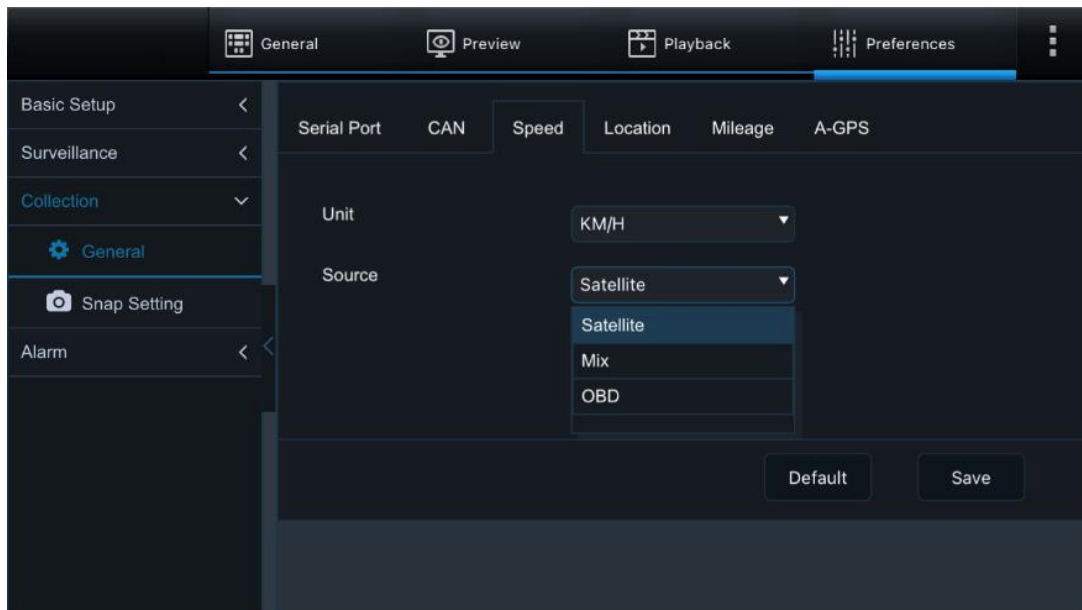

Figure 12: Screenshot of Speed Source Calibration.

Server connection status

	Server Status	Sensor Status	OBD Data	6 Axis Data
Basic Info	Central Server 1	Connected Status	Connected	
		Network Type	Communication Module 1	
		Protocol Type	N9M	
		Server Address	34.246.115.242	
Device Module		Port	5556	
	Central Server 2	Connected Status	Disconnected	
Storage Device		Network Type	Communication Module 1	

Figure 13: Screenshot of Server configuration and status.

Sensor status

	Server Status	Sensor Status	OBD Data	6 Axis Data
Basic Info	I01	IO Status	Low Level	
		IO Use	UnKnow	
Device Module	I02	IO Status	Low Level	
		IO Use	Null	
Storage Device	I03	IO Status	Low Level	
		IO Use	Null	
	I04	IO Status	Low Level	
		IO Use	Null	

Figure 14: Screenshot of Sensor status.

Vehicle registration information

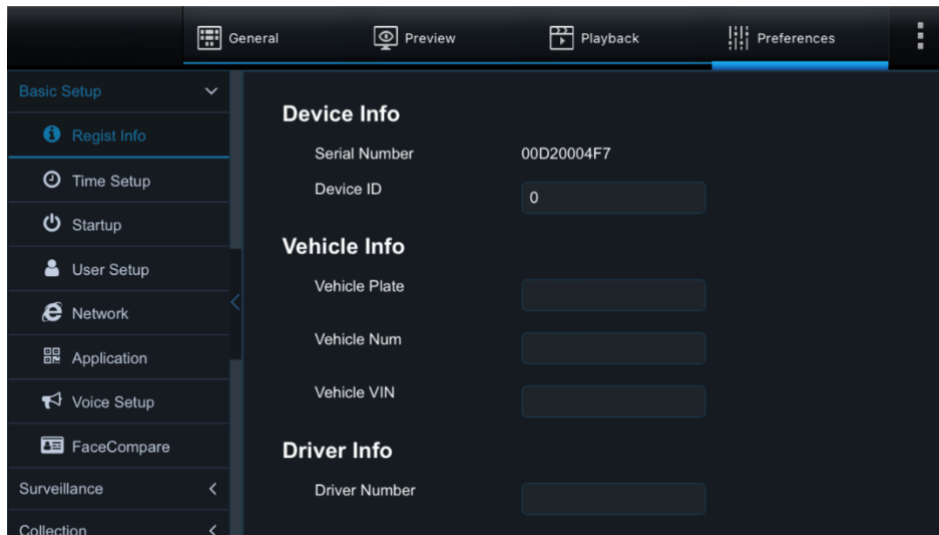

Figure 15: Screenshot: vehicle Information.

Camera Field Of View (FOV)

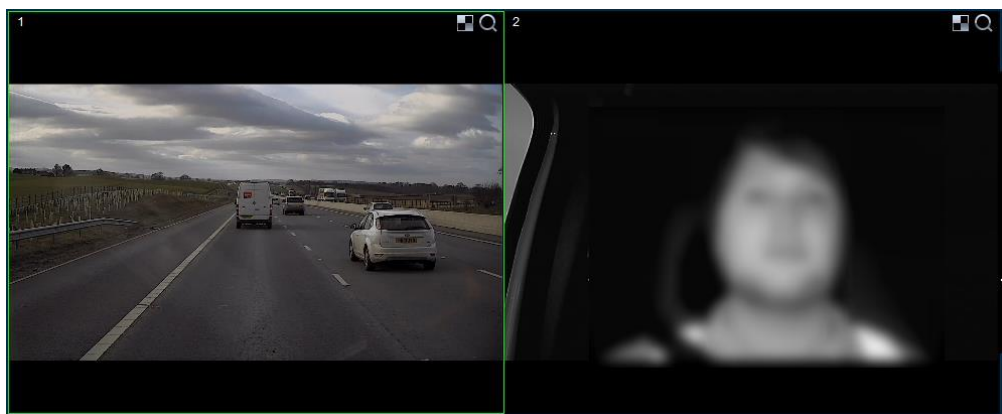

Figure 16: Screenshot of Frontal Camera

9 Installation Troubleshooting

Can't find the VisionAI Wi-Fi hotspot in the APP?

- Check that the device is powered on and receiving steady power. The Green light LED on the main unit indicates that the device is "ON".
- Main unit Wi-Fi works on AP (Access Point) mode only for 2 mins after each reboot and it will change to Client mode thereafter.

The system cannot start.

- Check the input power, whether the power wire is connected correctly, whether the ground wire is connected back to the battery, and whether the fuse on the power wire is in good condition.

- Check whether the ignition signal wire input to the power shows a voltage higher than 7V.

The device restarts uninterruptedly.

- Check whether the battery voltage is fluctuating. If it goes below the device's start-up voltage, the device will always restart.
- A faulty SD card may cause the device to restart. Remove the storage part and check whether it is damaged.

The device cannot record.

- Check whether the TF Cards are correctly installed, and whether they can be read normally in a computer.
- Check if the TF cards are formatted. The TF card should be formatted before normally storing record files.
- Check whether there is video signal input into the device from camera, and whether there is video/image on the screen.

There is no voice in record file?

- Access to Video Channel Settings, check if Audio is set to ON.
- There must be video input into the channel for recording and it must record normally.

The device cannot shut down in ignition switch mode.

- Check if the ignition line connection mode is correct; and check whether there is voltage on ignition yellow line when the key is turned off.
- If the device has been set with schedule recording, it can't shut down if it is still during recording time of the task table.

10 Firmware and Configuration upgrade

This step is only performed if required. By default, the devices shall come with the latest FW and configuration file pre-loaded per region from the factory.

FW upgrade to be done via Web application.

10.1 Firmware Upgrade

FW upgrade can be remotely performed using the Operation & Maintenance Platform as well as locally, using Internal Web configuration Tool.

The device currently supports the upgrade of six distinct FW packages:

- Device upgrade: FW of the main unit which also supports the optional external cameras.
- GPS Upgrade: FW of the GPS module
- R-Watch: FW of the IA Driver Coach device

- Power Box: FW of the intelligent power box
- Accousto: not available for the AD Plus 2.0
- 4G Upgrade: FW of the Quectel LTE Modem

Note: the FW upgrade for the External DSM driver camera can not be performed locally. Only the Remote upgrade is available.

Go to **Maintenance > Upgrade** and browse the required FW version and press **Upgrade**.

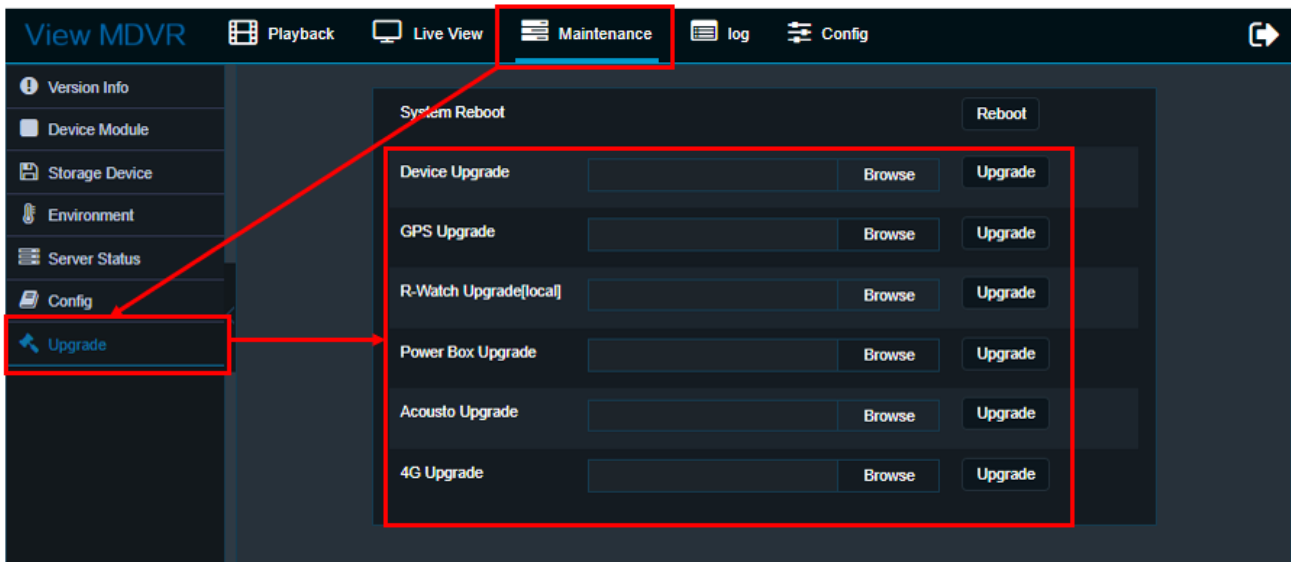
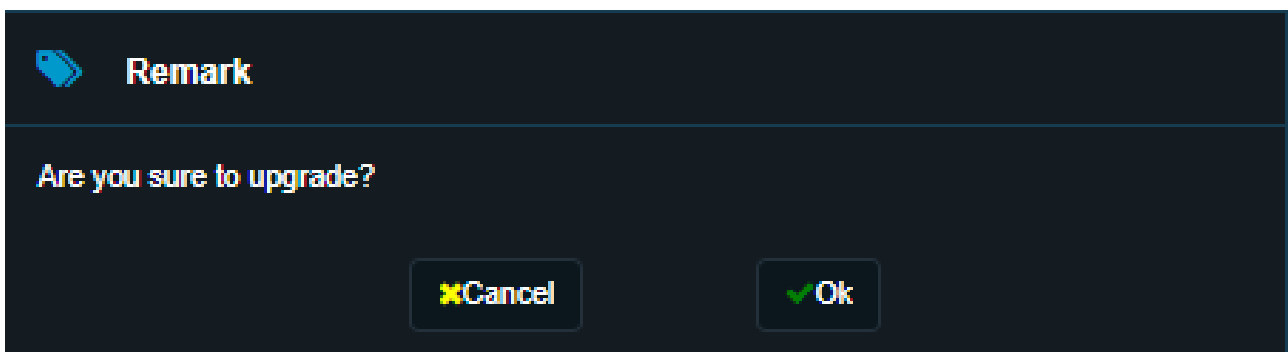

Figure 17: Selecting the SW versions to be upgrade.

A confirmation request is shown



By confirming the upgrade, a progress bar box shall appear, indicating the software upgrade progress. So not turn off the device during an upgrade.

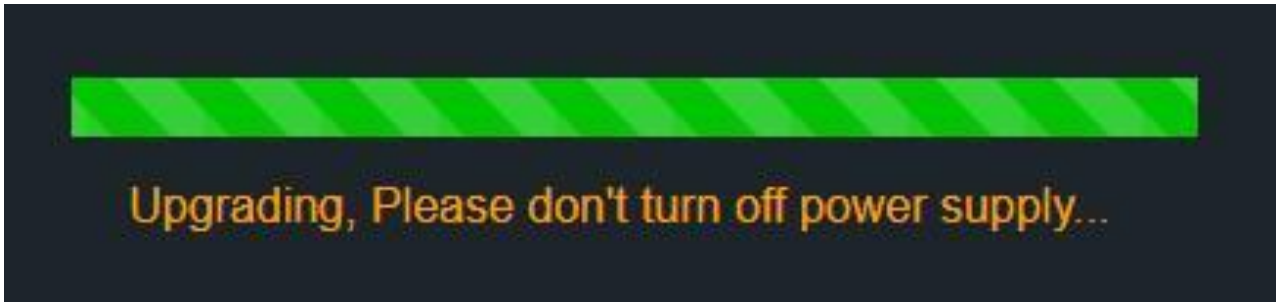

Figure 18: Upgrade status bar.

NOTE: depending on the SW being upgraded, the main unit may restart, and the Wi-Fi connection severed. After the Wi-Fi is available again, please reconnect your notebook to the device, to check if the upgrade was successfully completed.

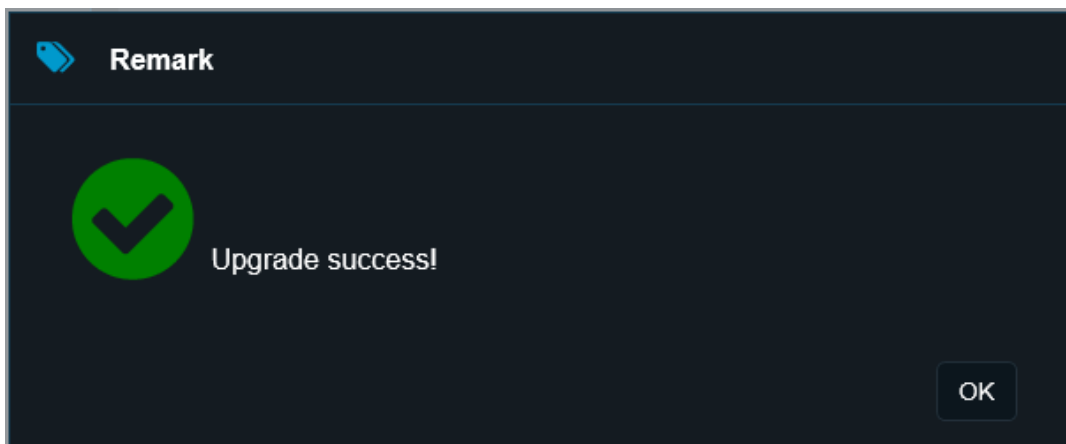

Figure 19: Update Success Message

An Error message box appears in case the selected FW version was already loaded

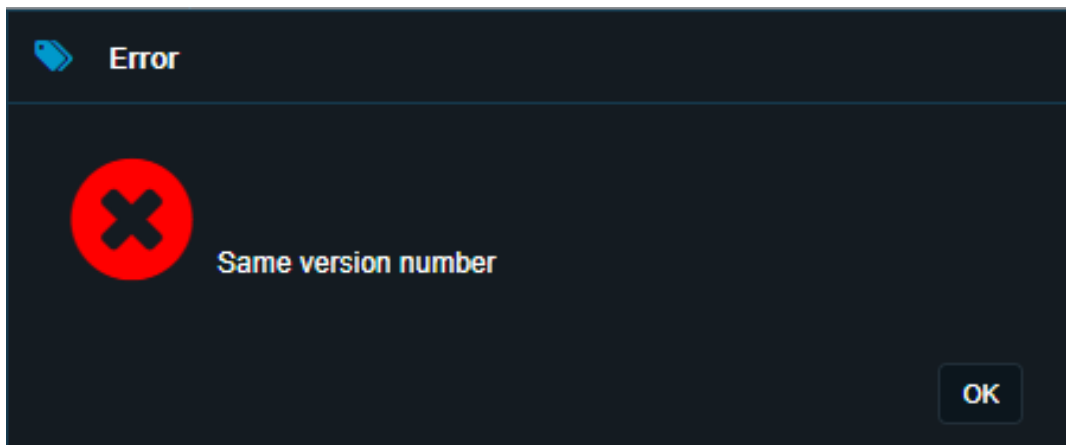

Figure 20: Error Message (version already installed).

10.1.1 Firmware and Configuration upgrade OTA (optional steps)

Over the air updates of Firmware and Configuration is possible. Before this step can be done the unit must have been calibrated and confirmed operation on MiX Fleet Manager.

Please log a SR if this is required as limited access to this platform is currently available.

10.1.2 Load FW via USB

With the AD Plus 2.0 you have the ability to load the FW file to a USB and the device will automatically apply and update the device with this file.

Create folder – *autoupgrade* on root of USB, add FW file in that folder.

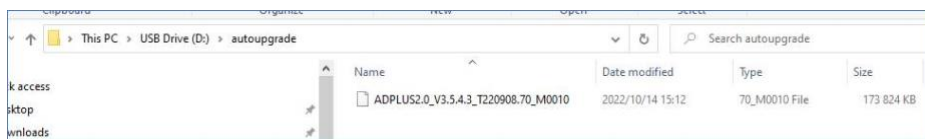

Plug USB in [Mini USB OTG Adaptor](#) and then in the powered up unit. The FW upgrade process will start and take about 6min.

10.2 Load Default Config

It is possible to load a standard configuration file using the local Web Configuration App.

On a Web-browser go to the URL: <http://192.168.240.1/login/default.html>

Enter default username and password. **admin/admin**

The latest Config file can be requested

Go to **Maintenance > Config > Import Parameters**. Browse the latest Config file and press **Upgrade**.

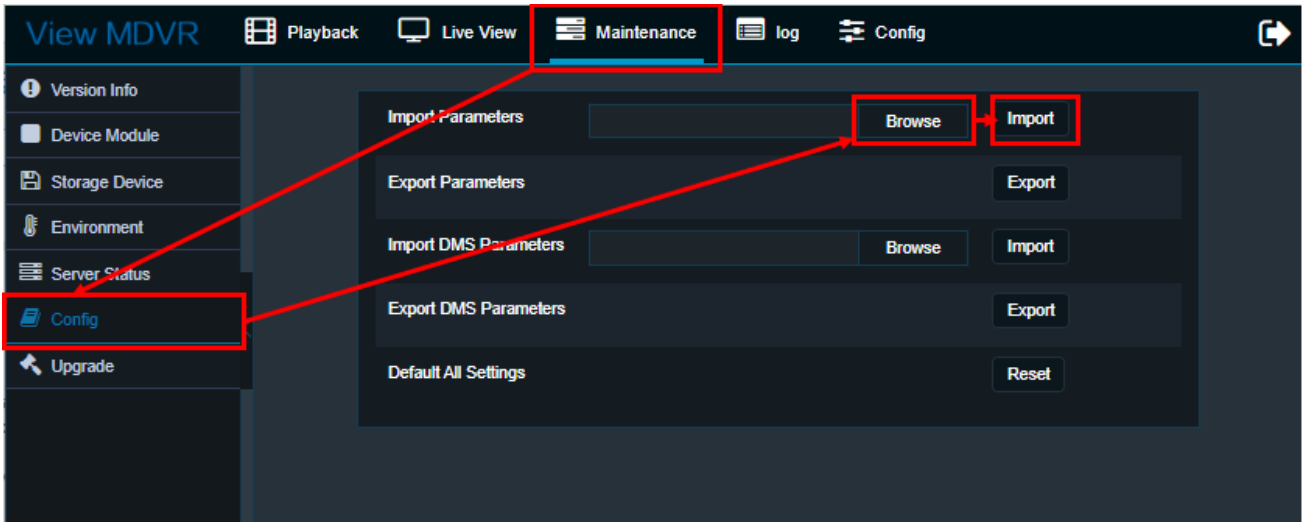

Figure 21: Updating the Device configuration.

10.3 APN Setup

Enter the APN details of the SIM Card your intent to use.

Default is “internet”

Go to **Config > Basic Setup > Network > Communication Module**. Change the APN details to that of your SIM provider and press **SAVE** to save the settings.

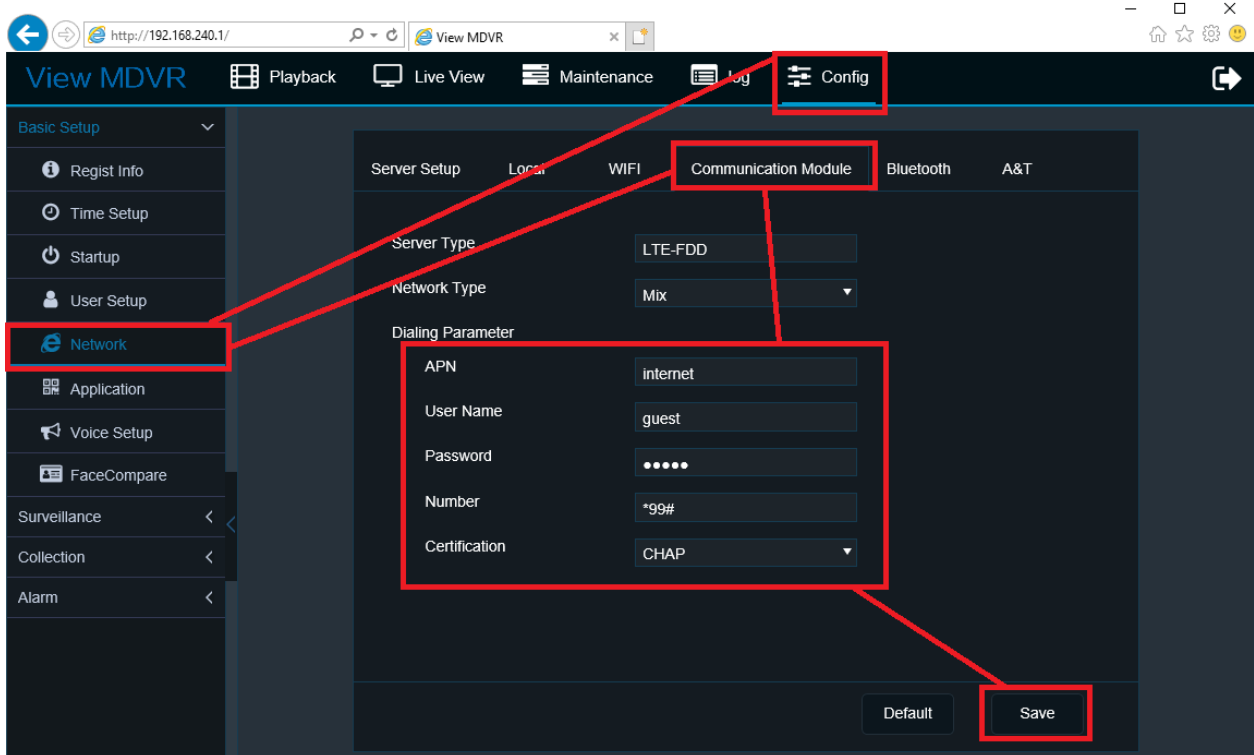

Figure 22: Setting up the APN.

-END-